

FNG van Kempen
Hoefbladhof 27
2215 DV Voorhout

DEC-11-HMFMA-B-D

**MF11-U/UP
core memory system
maintenance manual**

digital equipment corporation • maynard, massachusetts

1st Edition, September 1973
2nd Printing (Rev) March 1974
3rd Printing (Rev) November 1974

Copyright © 1973, 1974 by Digital Equipment Corporation

The material in this manual is for informational purposes and is subject to change without notice.

Digital Equipment Corporation assumes no responsibility for any errors which may appear in this manual.

Printed in U.S.A.

The following are trademarks of Digital Equipment Corporation, Maynard, Massachusetts:

DEC	PDP
FLIP CHIP	FOCAL
DIGITAL	COMPUTER LAB
UNIBUS	

11/74-15

CONTENTS

	Page
CHAPTER 1	MF11-U/UP CORE MEMORY GENERAL DESCRIPTION
1.1	INTRODUCTION 1-1
1.2	GENERAL DESCRIPTION 1-1
1.2.1	Introduction 1-1
1.2.2	Physical Description 1-1
1.2.3	Specifications 1-2
1.2.4	Functional Description 1-3
1.2.4.1	Introduction 1-3
1.2.4.2	Timing and Control Module 1-5
1.2.4.3	G114 Sense Inhibit Module 1-5
1.2.4.4	G235 Driver Module 1-6
1.2.4.5	H217D Stack Module 1-7
1.2.5	Basic Memory Operations 1-7
1.2.5.1	Data In (DATI) Cycle 1-7
1.2.5.2	Data In, Pause (DATIP) Cycle 1-8
1.2.5.3	Data Out (DATO) Cycle 1-8
1.2.5.4	Data Out, Byte (DATOB) Cycle 1-8
CHAPTER 2	16K UNIBUS TIMING MODULE
2.1	INTRODUCTION 2-1
2.2	MEMORY PROTECTION CIRCUITS 2-1
2.2.1	DC LO and BUS INIT 2-1
2.2.2	Loss of Bias Current 2-4
2.3	OPERATING MODE SELECTION LOGIC 2-5
2.3.1	Operating Modes 2-7
2.3.1.1	Master Sync 2-7
2.3.1.2	Slave Synchronization (SSYN) Circuit 2-7
2.3.1.3	Device Selection 2-7
2.3.1.4	Address Decoding 2-7
2.3.1.5	Mode Selection 2-8
2.3.1.6	DATI MODE (Read—Restore) 2-10
2.3.1.7	DATIP Mode 2-12
2.3.1.8	DATO (Clear—Write) 2-12
2.3.1.9	DATO 2-12
2.3.1.10	DATOB Mode 2-12
2.4	DEVICE AND WORD SELECTION 2-12
2.4.1	Introduction 2-12
2.4.2	Memory Organization and Addressing Conventions 2-13
2.4.3	Device Selector 2-14
2.4.4	Word Selection 2-17
2.4.4.1	Word Address Register 2-18
2.5	CONTROL LOGIC 2-18
2.5.1	Introduction 2-18
2.5.2	Timing Circuit 2-19
2.5.3	MATB START READ H Signal 2-20
2.5.4	MATB A EARLY L Signal 2-20
2.5.5	MATB LOCK MAR 1 L, MATB LOCK MAR 2 L Signals 2-21
2.5.6	MATB CLEAR MDR 0 L, MATB CLEAR MDR 1 L Signals 2-21

CONTENTS (Cont)

		Page
2.5.7	MATB CLK MDR 0 L, MATB CLK MDR 1 L Signals	2-21
2.5.8	MATB PAUSE H Signal	2-21
2.5.9	MATC READ EARLY L Signal	2-21
2.5.10	MATC END STROBE L Signal	2-22
2.5.11	MATC READ LATE L Signal	2-22
2.5.12	MATC OUTPUT ENABLE H Signal	2-22
2.5.13	BUS SSYN L Signal	2-22
2.5.14	MATC 300 NS DLY H Signal	2-22
2.5.15	MATD WRITE EARLY L Signal	2-22
2.5.16	MATD STACK CHG H Signal	2-22
2.5.17	MATD WRITE LATE L Signal	2-22
2.5.18	MATD INH TIME H Signal	2-22
2.5.19	WRITE LOCKOUT H Signal	2-23
2.5.20	MATD END OF WRITE L Signal	2-23
CHAPTER 3	DRIVER, SENSE AND STACK MODULES	
3.1	INTRODUCTION	3-1
3.2	CORE ARRAY	3-1
3.3	MEMORY OPERATION	3-1
3.4	X AND Y DECODING	3-4
3.5	DRIVERS AND SWITCHES	3-4
3.5.1	Word Address Decoding and Selection Sequence	3-8
3.6	READ/WRITE CURRENT GENERATION AND SENSING	3-9
3.6.1	Introduction	3-9
3.6.2	Read/Write Operations	3-9
3.6.3	X and Y Current Generators	3-12
3.6.4	Inhibit Driver	3-14
3.6.5	Sense Amplifier	3-16
3.6.6	Memory Data Register	3-16
3.7	STACK CHARGE CIRCUIT	3-16
CHAPTER 4	MF 11-UP CORE MEMORY WITH PARITY	
4.1	INTRODUCTION	4-1
4.2	DESCRIPTION	4-1
4.3	SPECIFICATIONS	4-2
4.4	FUNCTIONAL DESCRIPTION	4-3
4.4.1	DATI or DATIP Cycle	4-3
4.4.2	DATO Cycle	4-4
4.4.3	DATOB Cycle	4-4
4.4.4	Jumper Terminals	4-4
4.5	PROGRAMMING	4-5
4.6	BUS LOADING	4-5
4.7	INTERNAL BUS	4-6
4.8	POSSIBLE INTERLEAVING CONFIGURATIONS	4-6
4.9	ADDRESS SELECTION	4-6

CONTENTS (Cont)

	Page
CHAPTER 5	INSTALLATION AND MAINTENANCE
5.1	INTRODUCTION 5-1
5.2	INSTALLATION 5-1
5.2.1	Mounting Box and Power System 5-1
5.2.2	Jumper Configuration 5-4
5.2.3	Installation Procedure 5-5
5.3	PREVENTIVE MAINTENANCE 5-7
5.3.1	Visual Inspection 5-7
5.3.2	Voltage Measurements 5-7
5.3.3	Sense Strobe Delay Check 5-7
5.3.4	Drive Current Checks 5-8
5.3.5	PCL SSYN DLY Check (for parity memories only) 5-8
5.3.6	Strobe and Drive Current Margins 5-8
5.3.7	MAINDEC Testing 5-8
5.4	CORRECTIVE MAINTENANCE 5-8
5.4.1	Voltage Adjustment Procedure 5-8
5.4.2	Sense Strobe Delay and Drive Current Adjustments 5-8
5.4.3	PCL SSYN DLY L Adjustment Procedure 5-9
5.4.4	Corrective Maintenance Aids 5-9
5.5	MAINDEC TESTING 5-9
5.5.1	0-124K Memory Exerciser (MAINDEC-11-DZQMB) 5-10
5.5.2	0-124K Memory I/O Exerciser (MAINDEC-11-DZQMA) 5-10
5.5.3	Combined Parity Memory Tests (MAINDEC-11-DCMFA) 5-10
APPENDIX A	IC DESCRIPTIONS
A.1	741 HIGH PERFORMANCE OPERATIONAL AMPLIFIER A-2
A.2	7442 4 LINE TO 1 LINE DECODER A-3
A.3	7475 4-BIT BISTABLE LATCH A-5
A.4	7483 4-BIT BINARY ADDER A-7
A.5	7485 4-BIT COMPARATOR A-10
A.6	7528 SENSE AMPLIFIER A-12
A.7	82S62 9-BIT PARITY GENERATOR AND CHECKER A-14
A.8	74121 MONOSTABLE MULTIVIBRATOR A-15
A.9	74154 4-LINE TO 16-LINE DEMULTIPLEXER A-17
A.10	75325 MEMORY DRIVERS A-20

ILLUSTRATIONS

Figure No.	Title	Page
1-1	Module Utilization Chart	1-2
1-2	MF11-U/UP Simplified Block Diagram	1-4
2-1	MF11-U Detailed Block Diagram	2-3
2-2	Memory Protection Circuits	2-4
2-3	Bias Current Detection Circuit	2-4
2-4	Switch and Driver Selection	2-8
2-5	DATI Mode Timing Diagram	2-9
2-6	DATIP Mode Timing Diagram	2-9
2-7	DATO, DATOB Mode Timing Diagram	2-10
2-8	Memory Organization	2-14
2-9	Address Assignments for Three Banks of 16K Words Each	2-15
2-10	Device and Word Address Selection Logic Block Diagram	2-18
2-11	Read Timing Sequence	2-19
2-12	Write Timing Sequence	2-20
3-1	Three-Wire Memory Configuration	3-2
3-2	Hysteresis Loop for Core	3-3
3-3	Three-Wire 3D Memory	3-5
3-4	Simplified Y Line Selection Stack Diode Matrix	3-6
3-5	Typical Y Line Read/Write Switches and Drivers	3-7
3-6	Interconnection of Unibus, Data Register, Sense Amplifier and Inhibit Driver	3-10
3-7	Sense Operation Timing Diagram	3-11
3-8	Bias Current Supply and Read X Current Generator	3-13
3-9	Sense Amplifier and Inhibit Driver	3-15
3-10	Type 7528 Dual Sense Amplifiers with Preamplifier Test Points	3-16
3-11	Stack Charge Circuit	3-17
4-1	Parity Controller Internal Bus	4-1
4-2	Parity Controller Block Diagram	4-2
5-1	New MF11-U Power Distribution System	5-2
5-2	Early MF11-U Power Distribution System	5-3
5-3	Sense Strobe Delay Waveform	5-7
5-4	SSYN DLY L Timing Waveform	5-9
5-5	Troubleshooting Chart	5-11
5-6	Typical Sense/Inhibit Circuit (D00)	5-12
5-7	Sense Inhibit Module Waveforms	5-13
5-8	Typical Read/Write Drive Circuit	5-17
5-9	Drive Module Waveforms	5-18
5-10	M8293 16K Unibus Timing Module	5-21
5-11	G114 Sense Inhibit Module	5-22
5-12	G235 X-Y Driver Module	5-23
5-13	H217 Stack Module	5-24
5-14	M7259 Parity Control Module	5-25

TABLES

Table No.	Title	Page
1-1	MF11-U Memory Specifications	1-3
2-1	Selection of Bus Transaction	2-5
2-2	Generation of Memory Operating Signals	2-6
2-3	Addressing Functions	2-13
2-4	Device Address Jumpers (Non-Interleaved)	2-16
2-5	Device Address Jumpers (Interleaved)	2-17
3-1	Example of Word Address Decoding Signals	3-8
4-1	M7259 Parity Controller Specifications	4-2
4-2	MF11-UP Maximum Cycle and Access Times	4-3
4-3	M7259 Jumper Terminals	4-4
4-4	M7259 Parity Controller CSR Address Selection	4-7
4-5	CSR Addressing	4-9
5-1	Machine Serial Numbers for New and Earlier Power Distribution Systems	5-4

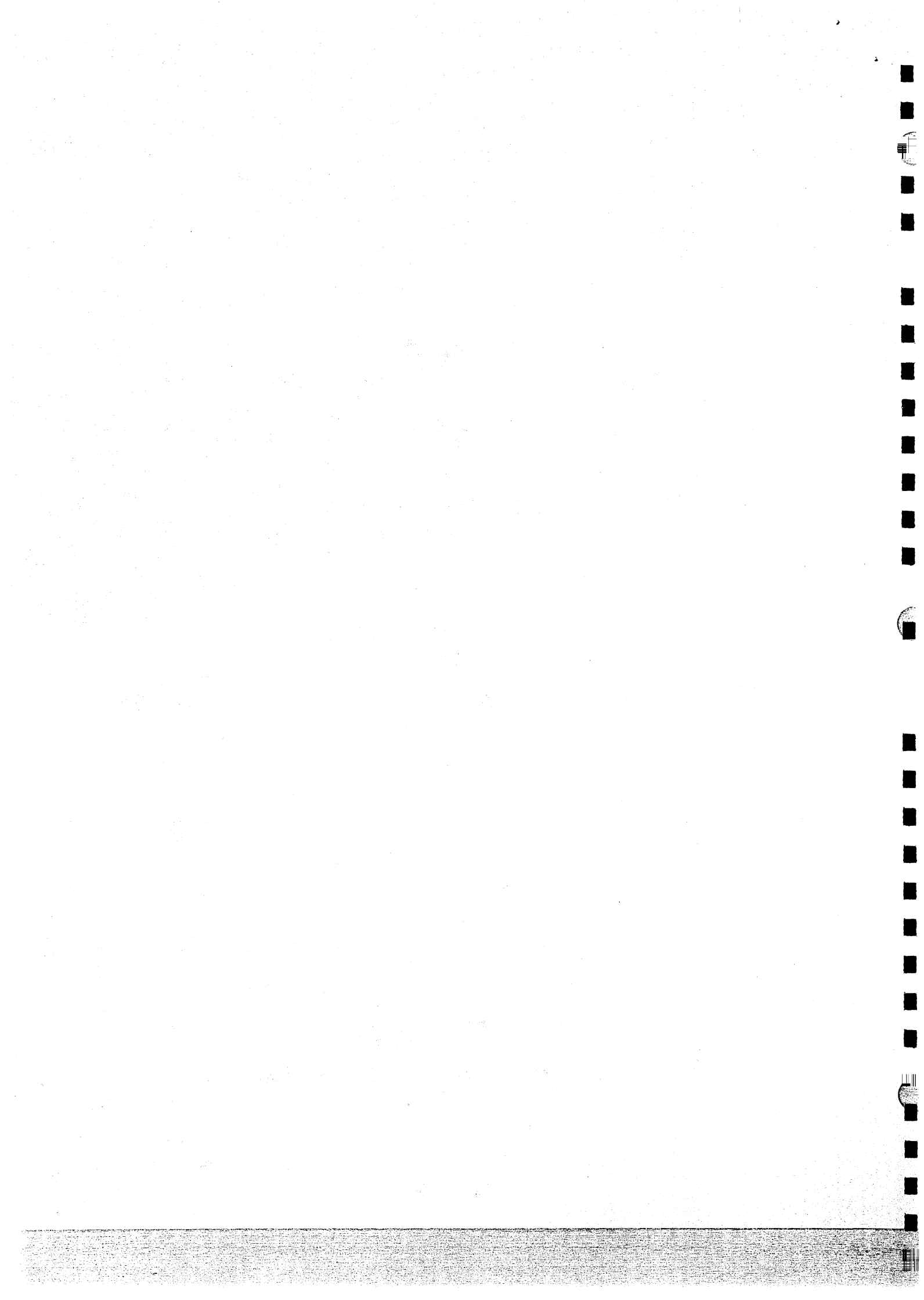

CHAPTER 1

MF11-U/UP CORE MEMORY

GENERAL DESCRIPTION

1.1 INTRODUCTION

This manual provides the user with the theory of operation and logic diagrams necessary to understand and maintain the MF11-U Core Memory (no parity) or the MF11-UP Core Memory (with parity). The level of discussion assumes that the reader is familiar with basic digital computer theory. Both general and detailed descriptions of the core memory are included.

Although memory control signals and data pass through the Unibus, it is beyond the scope of this manual to describe the operation of the Unibus itself. A detailed description of the Unibus is presented in the *PDP-11 Peripherals Handbook*.

A complete set of engineering logic drawings are shipped with each core memory. These drawings are bound in a separate volume entitled *MF11-U 16K Core Memory and Control, Engineering Drawings*. The drawings reflect the latest print revisions and correspond to the specific memory shipped to the user.

1.2 GENERAL DESCRIPTION

1.2.1 Introduction

This paragraph provides a physical description and specifications for the memory. The major functional units of the memory are briefly described and the basic memory operations are discussed.

1.2.2 Physical Description

The MF11-U provides 16,384 (16K) 16-bit words and the MF11-UP provides the same number of words but includes byte parity. Chapter 4 describes the differences between the MF11-U and MF11-UP memory. The chart below shows the various option descriptions associated with the 16K memory.

MF11-U	M8293 16K Unibus Timing Module G114 Sense Inhibit Module G235 X-Y Driver H217D Stack Module (16 bits) 7009295 Backplane Assembly
MM11-U Module Set	Includes all modules listed in MF11-U but does not include backplane assembly
MF11-UP	M8293 16K Unibus Timing Module G114 Sense Inhibit Module G235 X-Y Driver Module H217C Stack Module (18 bits including parity) 7009295 Backplane Assembly M7259 Parity Control Module

MM11-UP Module Set

Includes all modules listed in MF11-UP
except M7259 Parity Control Module and
does not include backplane assembly

If a user has a 16K memory system and wishes to add another 16K, he merely specifies the appropriate module set since the existing backplane assembly can hold 32K of memory. The modules are plugged into the slots designated in Figure 1-1.

NOTE

Parity memory cannot be mixed with non-parity memory on the same backplane.

	1	2	3	4	5	6	7	8	9
A	UNIBUS IN	M7259 PARITY							UNIBUS OUT
B									
C	M8293 16K UNIBUS TIMING		6114 SENSE INHIBIT	H217D MEMORY*	G235 X-Y DRIVER	G235 X-Y DRIVER	H217D MEMORY*	6114 SENSE INHIBIT	
D		BLANK							
E									
F									M8293 16K UNIBUS TIMING

* For MF11-UP (parity memory), Memory Stack H217C is used. Viewed from Backplane.

11-2087

Figure 1-1 Module Utilization Chart

1.2.3 Specifications

The general MF11-U memory specifications are listed in Table 1-1. Refer to Chapter 4 for additional MF11-UP specifications.

Table 1-1
MF11-U Memory Specifications

Type: Magnetic core, read/write, coincident current, random access

Organization: Planar, 3D, 3-wire

Capacity: 16,384 (16K) words for MM11-U (16-bit word)

Maximum Access Time and Cycle Time:

Bus Mode	Cycle Time	Access Time
DATI	1000 ns	425 ns
DATIP	425 ns	425 ns
DATO-DATOB (PAUSE L)	1000 ns	125 ns
DATO-DATOB (PAUSE H)	680 ns	100 ns

X-Y Current Margins: $\pm 6\%$ @ 0° C, $\pm 7\%$ @ 25° C, $\pm 6\%$ @ 50° C

Voltage Requirements: +5 V $\pm 5\%$ with less than 0.2 V ripple
+20 V $\pm 5\%$ with less than $\pm 5\%$ ripple
-5 V $\pm 5\%$ with less than $\pm 5\%$ ripple

Average Current Requirements: Stand by: +5 V: 5.38 A -5 V: 0.41A
+20 V: 0.5A

Memory Active: +5V: 6.1A -5 V: 0.51A
+20 V: 3.4A

Power Dissipation (Worst Case): M8293 Control Module ~ 7 W
G235 Drive Module ~ 33 W
H217D Stack Module ~ 40 W
G114 Sense Inhibit Module ~ 40 W
Total at Maximum Repetition Rate: 120 W

Environment:
Ambient Temperature: 0° C to 50° C (32° F to 122° F)
Relative Humidity: 0-90% (non-condensing)

1.2.4 Functional Description

1.2.4.1 Introduction – The MF11-U/UP Memory is a read/write, random access coincident current, magnetic core type with a maximum cycle time of 980 ns and a maximum access time of 425 ns. It is organized in a 3D, 3-wire planar configuration. Word length is 16 bits and the memory consists of 16,384 (16K) words.

The memory can be interleaved in 32K increments for faster operation. Interleaving causes consecutive bus addresses to be located within alternate 16K memory blocks.

The major functional units of the memory (Figure 1-2) are briefly described in the following paragraphs.

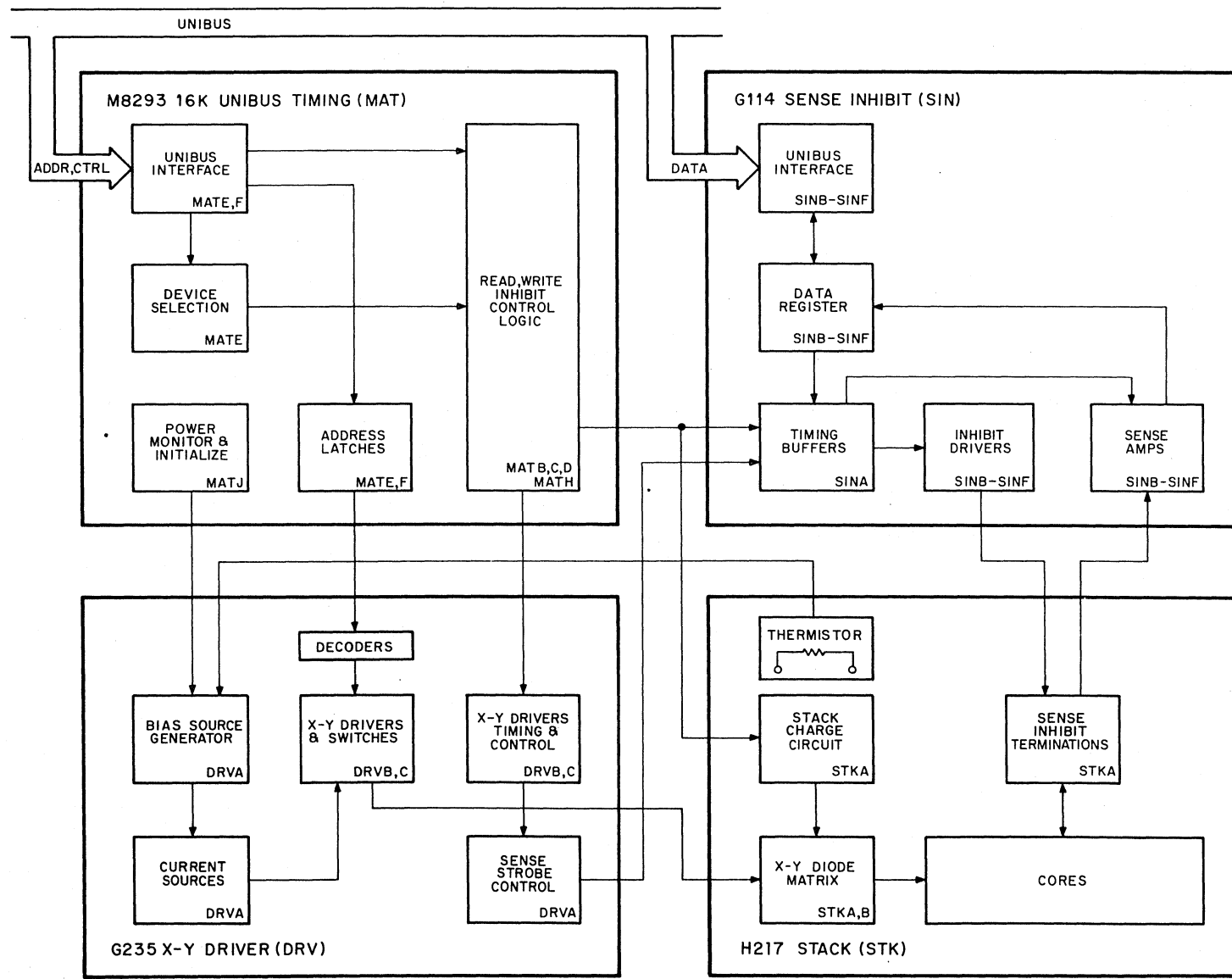

11-1747

Figure 1-2 MF11-U/UP Simplified Block Diagram

1.2.4.2 Timing and Control Module – The 16K Unibus Timing Module (M8293) contains the control and address portion of the Unibus interface, device selection, power monitor, read-write-inhibit control logic, and the memory address latches.

Unibus Interface – The Unibus interface accepts address and control information from the Unibus. The address information is distributed to the device selector and the address latches. The control signals are supplied to the read, write, and inhibit control logic to initiate the read or write currents in memory. The control signals are BUS C00 and BUS C01 and specify the type of data transfer (DATI, DATIP, DATO, DATOB). If a byte operation (DATOB) is specified, A00L is examined and specifies the appropriate byte.

Device Selection – The device selection logic compares the Unibus address with a prewired jumper configuration. If the address compares, a memory cycle is initiated on the receipt of MSYN. If the address does not compare with the jumper address, the Unibus has addressed some other device and no memory cycle is initiated.

Read-Write-Inhibit Control Logic – The read-write-inhibit control logic operates the timing and control signals to turn on the read, write, and inhibit currents in memory. This is accomplished by propagating a voltage pulse through delay lines and setting and resetting flip-flops as the pulse is propagated through the delay lines. The logic also provides clocking and clearing controls for the data register and controls the time at which the data and SSYN are placed on or taken off the Unibus. In addition, a locking function is provided to lock the address and control information into address latches for use during the memory cycle.

Address Latches – The address latch logic consists of 7475 quad latches (Appendix A) which store the address received from the Unibus for the device selector and stack address decoding circuits. When memory is not busy, the latches are left open and the output merely follows the input. When memory is busy, the output is latched to its previous state. This preserves the address during a memory cycle so that the processor can process other devices without being delayed by the memory.

Power Monitor and Initialize – The power monitor and initialize logic is initiated as a result of BUS INIT or DC LO from the Unibus. Both conditions indicate that further memory operations are to be discontinued. A 2 μ s delay is provided to allow memory to complete the current cycle, then current sources are inhibited.

NOTE

The MF11-U/UP incorporates an M8293 16K Unibus Timing Module (Chapter 4); other memory systems may employ a different timing and control module although the driver, sense inhibit and stack modules will be the same. Consult the applicable configuration chart in the logic print set.

1.2.4.3 G114 Sense Inhibit Module – The G114 Sense Inhibit Module contains the data portion of the Unibus interface, the data register, timing buffers, inhibit drivers, sense amplifiers and threshold circuit.

Unibus Interface – The data portion of the Unibus interface consists of type 380 Receivers which apply Unibus data to the data input of the data register (information register). This register is clocked under control of the timing signals from the 16K Unibus Timing Module. Also, the Unibus interface supplies data from the data register to the Unibus via 8881 bus drivers under control of these timing signals.

Data Register – The data register is a 16-bit flip-flop register used to store the contents of a word after it is destructively read from memory; the same word can then be written back into memory (restored) when in the DATI mode. The register is also used to accept data from the Unibus lines to accommodate the loading of incoming data into the core memory during the DATO or DATOB cycles.

Timing Buffers – The timing buffers are used to buffer the timing signals between the timing and control board and the G114 Sense Inhibit Module.

Inhibit Drivers – Each bit mat contains a single inhibit/sense line that passes through all cores on the mat. A bit mat in the MM11-U is a core array of 16,384 cores associated with a particular bit position in all the words in memory. To write a 0 into a selected bit, an inhibit current is passed through the inhibit/sense line that cancels the write current in the Y line. The core does not switch, so it remains in the 0 state. Cores are left in the 0 state at the end of the read portion of the cycle. With no inhibit current, the currents in the X and Y lines switch the core to the 1 state during write sequences.

Sense Amplifiers Threshold – During a read operation, the sense amplifier picks up a voltage induced in the sense/inhibit winding when a core is switched from a 1 to a 0. This signal is detected and amplified by the sense amplifier whose output sets a data register flip-flop to store a 1. In effect, a 1 is read when the core is switched to the 0 state. Cores which were previously set to 0 do not switch and are not affected.

The threshold circuit provides a reference threshold voltage to the sense amplifiers. In a read operation, if the threshold voltage (17 mV) is exceeded during sense strobe time, the sense amplifier produces an output.

1.2.4.4 G235 Driver Module – The G235 Driver Module contains the decoders, X and Y drivers and switches, associated timing and control for the X and Y drivers, sense strobe control, bias source generator, and current sources.

Decoders – The decoders decode 14 of the 18 bits of the Unibus address. Seven of the 14 address bits are used for X address selection and seven are used for Y address selection. Four of the seven X bits are applied to the X switches and three to the X drivers. The same situation occurs for the Y drivers. The four bits not sent to the decoders are used for decoding device selection and byte operation. The decoded X and Y bits ultimately specify one core out of 16,384 for each bit of a 16-bit word.

Switches and Drivers – The switches and drivers direct the flow of current through the magnetic cores to ensure the proper polarity for the desired function. This action is necessary because a single X read/write line is used, a single Y read/write line is used, and the current for a write operation is opposite in polarity to the current required for a read operation. There are separate switches and drivers for the read and write circuits in the selection matrix.

Drivers Timing and Control – The drivers timing and control logic receives inputs from the timing and control module and combines the timing signals to derive specific timing pulses and proper timing relationships required by all X-Y drivers and switches as well as current sources.

Sense Strobe Control – The sense strobe control is a one-shot multivibrator whose duration can be controlled by an external voltage input. The control determines when the sense amplifiers are examined.

NOTE

A factory adjustment is made by cutting certain jumpers to determine the optimum position for the sense strobe to occur. Sophisticated test equipment is used in making this factory adjustment and changing the jumper configuration will result in less than optimum memory performance.

Pin AV1 on the G235 Driver Module is designated "strobe margin." This pin is normally left open and floats to approximately 2.5 V. However, a voltage can be applied to ensure that the memory has adequate sense strobe margins (ground for early strobe, +5 V for late strobe).

Bias Source Generator – The bias source generator is a dc, temperature compensated, bias current used to control the amplitude of the current from the X and Y current generators and inhibit current sources.

Current Sources – X and Y current generators provide the current necessary to change the state of the magnetic cores. The rise time and amplitude of the output-current waveform have been selected to provide optimum switching of the core states and maximum signal-to-noise ratio for a wide range of temperatures.

1.2.4.5 H217D Stack Module – The H217D Stack Module contains the ferrite core array, X-Y diode matrices, sense/inhibit terminations, stack charge circuit, and a thermistor to provide temperature compensation for the bias current.

Ferrite Core Array – The core array is contained on the H217D Stack Module and consists of a planar array 128 X 128 X 16 mats, or a total of 262,144 cores.

X-Y Diode Matrix – The X-Y diode matrix is used in conjunction with the drivers and switches and is used to select one of 128 X lines and one of 128 Y lines.

Sense Inhibit Terminations – The sense inhibit terminations terminate the sense inhibit lines in order to minimize transmission line reflections. This is necessary in order that the sense amplifiers can sense core switching with minimum distortion.

Stack Charge Circuit – The stack charge circuit is used to bias the X and Y drive lines to near ground potential during read time, and to near +20 V during write time. The purpose of this is to back-bias the diodes on the X-Y matrix to prevent loss of drive currents due to charging capacitance through unselected diodes.

1.2.5 Basic Memory Operations

The core memory has four basic modes of operation. The main function of the memory is simply to read or write data. Additional modes are provided, however, to allow for byte operation and to postpone the restore cycle in a read-modify-write (DATIP/DATO) cycle. The four basic memory operations are:

- a. read/restore (DATI)
- b. read pause (DATIP)
- c. write (DATO)
- d. write byte (DATOB)

These four modes are discussed briefly in the following paragraphs.

NOTE

In the following discussions, all operations refer to the master (controlling) device. For example, the term data out indicates data flowing out of the master and into the memory.

1.2.5.1 Data In (DATI) Cycle – The DATI cycle is a read/restore memory cycle. During this operation, the memory reads the information from the selected core location, transfers it to the Unibus, and then writes the information back into the memory location. This last step is necessary because the core memory is a destructive readout device. During the first (read) part of the cycle, the memory strobes the data into a data register and then gates the data to the Unibus. Then, during the second (write) part of the cycle, the memory restores the data back into the addressed memory location.

1.2.5.2 Data In, Pause (DATIP) Cycle – Since the data is destroyed when reading from a particular memory location, it must be restored. However, sometimes it is not desirable to restore the information immediately after reading because the location is to have new data written into it. In this instance, eliminating the restore operation decreases the memory cycle time by approximately 50 percent. The DATIP operation is used for this purpose. The data is read from memory and the restore cycle is inhibited. Because no restore cycle is used, a DATIP must always be directly followed by a write cycle (either DATO or DATOB) on the same address, or data in both addresses will be destroyed.

1.2.5.3 Data Out (DATO) Cycle – The DATO cycle is a write memory cycle used by the master device to transfer data into core memory. To ensure that proper data is stored, the bus data is first clocked into the data register, then the memory location is cleared by reading the cores (thereby setting them all to 0) before writing in the new data. During a normal DATO, the memory first performs the read operation to clear the cores and then performs a write cycle to transfer data from the data register into the selected core location. If a DATO follows a DATIP (rather than a DATI), the sequence is not the same. The DATIP clears core and generates a pause flag; the DATO skips the read cycle and immediately begins the write cycle. This process reduces DATO cycle time by approximately 40 percent. Note that access time is the same (Table 1-1).

1.2.5.4 Data Out, Byte (DATOB) Cycle – The DATOB cycle is similar in function to the DATO cycle, except that during DATOB, data is transferred into the core memory from the bus in byte form rather than as a full word. Actually, an entire word is loaded into the selected memory location: the selected byte, which is new data from the bus; and the non-selected byte, which is restored data from the word previously stored in that memory location. During the read cycle, the non-selected byte is saved by reading it into the data register while the selected byte is transferred into the data register from the Unibus. During the write cycle, the word is loaded into the memory location from the data register. In effect, the memory is read first and then simultaneously performs a restore cycle for the non-selected byte and a write cycle for the selected byte. The mode can follow a DATIP as described above.

CHAPTER 2

16K UNIBUS TIMING MODULE

2.1 INTRODUCTION

This chapter describes the M8293 16K Unibus Timing Module employed with the MF11-U/UP Core Memory system. The chapter is divided into three major sections – memory protection circuits, operation mode selection logic, and control logic. This circuitry is shown on diagram M8923-0-1. Figure 2-1 represents a detailed block diagram of the memory and depicts how the 16K Unibus timing is tied into the core memory system.

2.2 MEMORY PROTECTION CIRCUITS

The memory protection circuits contain the logic to detect BUS INIT L and DC LO L from the Unibus. They also contain the circuitry to detect loss of bias current.

2.2.1 DC LO and BUS INIT

One of the functions of the M8293 16K Unibus Timing Module is to detect BUS INIT L and DC LO L from the Unibus. Either signal causes MATJ MSYN HOLDOFF H to be asserted (Figure 2-2). This signal inhibits the initiation of any new memory cycles. A delay circuit consisting of Q1 and Q2 and associated external components (sheet MATJ of M8293-0-1) causes MATJ IZ L and MATJ IZ H to be generated after a 3 μ s delay. The IZ signals are used to initialize the 16K Unibus timing module, while the 3 μ s delay allows the memory to complete any current cycles that were in progress at the time of BUS INIT L or DC LO L. In addition, MATJ IZ L is applied to Q11 on the G235 Driver Module causing Q11 to conduct and Q10 to go to saturation. This drives PWR OK H low (Figure 2-3) and inhibits the X-Y current generators (Q1 through Q4). Transistor Q9 is turned off so that DRVA PWR OK L is no longer asserted. On the G114 Sense Inhibit Module, this drives Q1 (G114-0-1, sheet 3) into saturation and asserts SINA POWER FAIL L which prevents the inhibit drivers (G114-0-1, sheets 4 through 8) from turning on.

NOTE

With DC LO L asserted, the operation occurs as described above even though the +5 V and -5 V power supplies are turned off. The memory protection circuits will operate even if the +20 V power supply is just above +5 V. If the +20 V supply produces less than +5 V, the circuits may not operate properly; this makes no difference, however, as no substantial driver currents are generated.

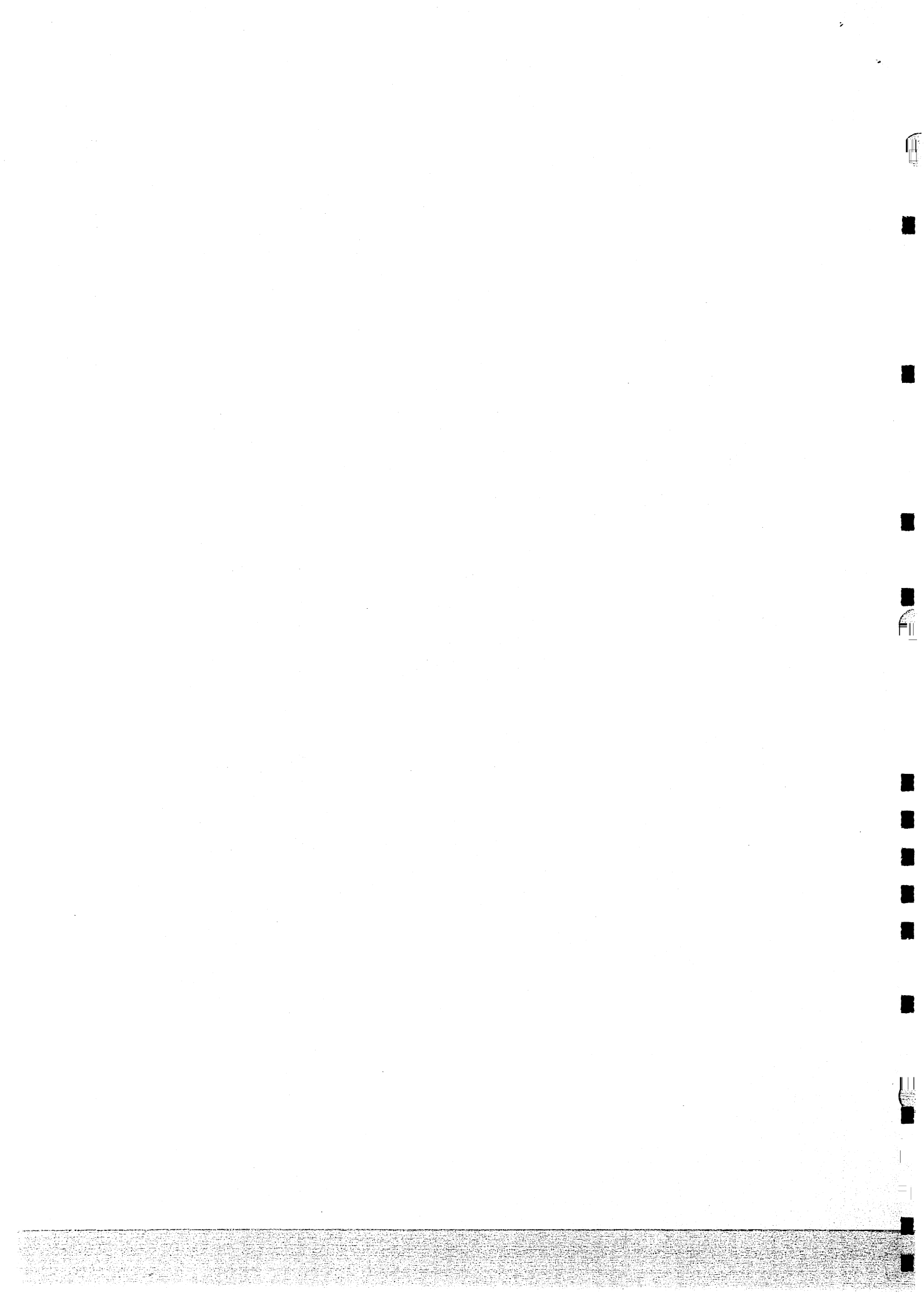

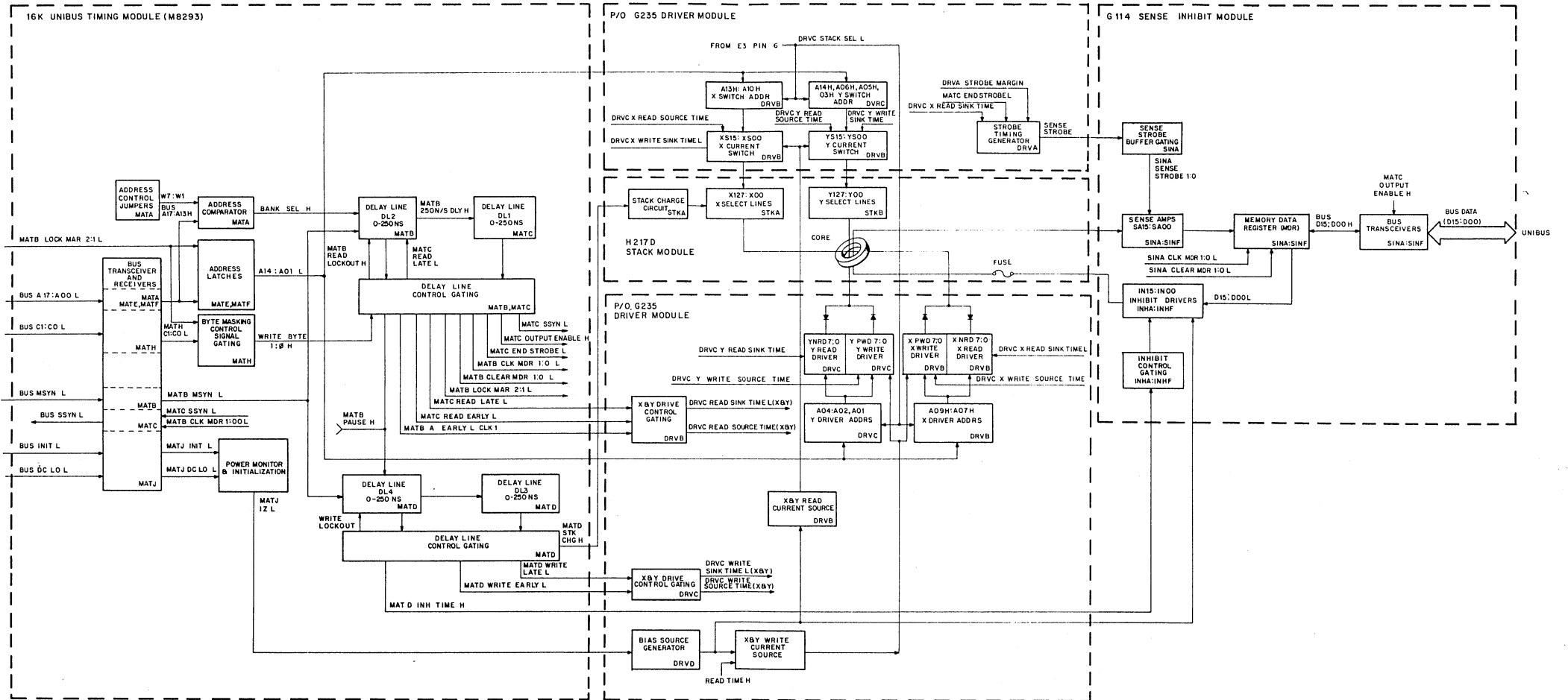
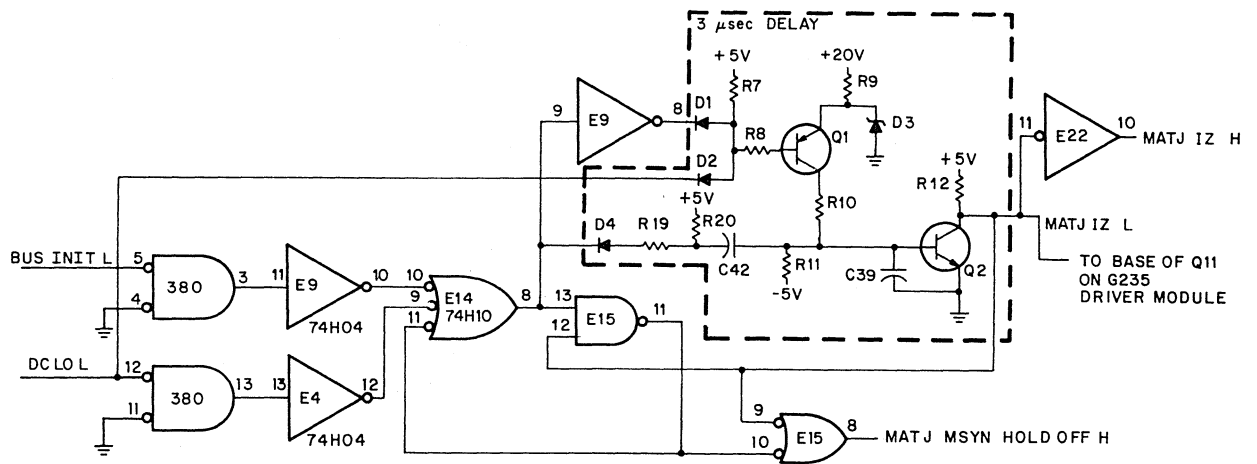
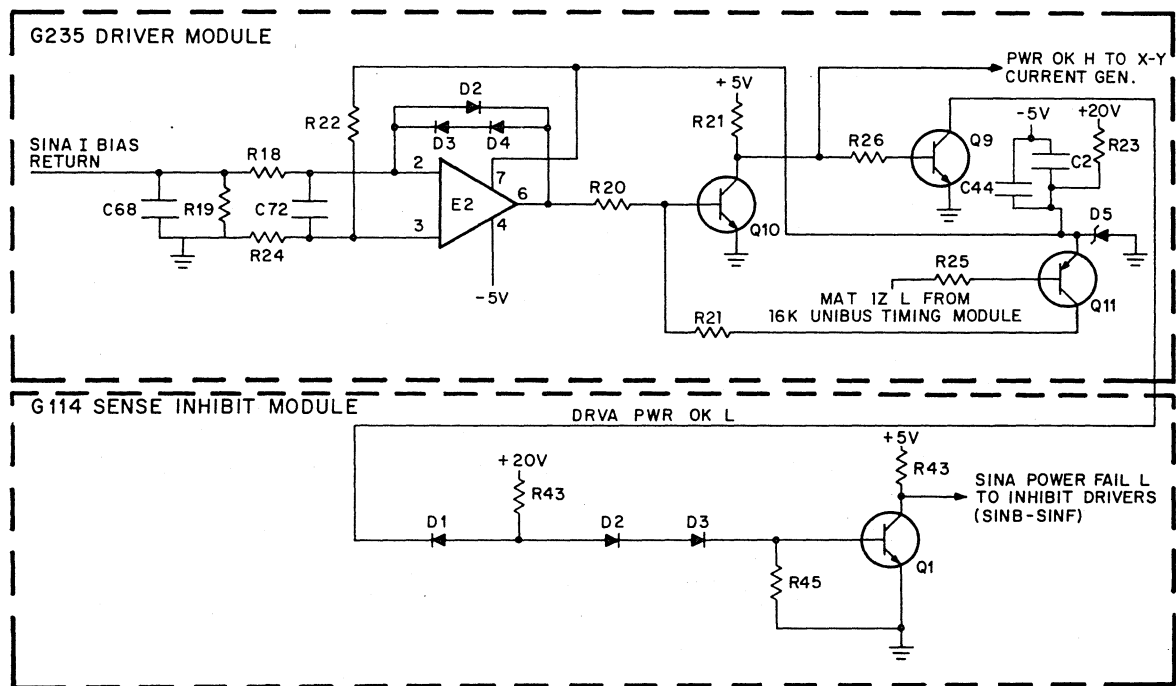

Figure 2-1 MF11-U Detailed Block Diagram



11-1750

Figure 2-2 Memory Protection Circuits



11-1749

Figure 2-3 Bias Current Detection Circuit

2.2.2 Loss of Bias Current

If there is a loss of bias current, the current generators (G235-0-1, sheet 6) must be inhibited from turning on. If the current generators are turned on without bias current, it is possible that the saturating transformers may not sufficiently limit the inhibit current. The bias current source is applied to the inhibit drivers on the G114 Sense Inhibit Driver Module and is returned to the 16K Unibus timing module as a SINA I BIAS RETURN signal. This signal is detected by the differential amplifier in Zone C-7 (Figure 2-3). The bias current is returned to ground through R19, generating a slight voltage across R19 which is detected by the differential amplifier. If the voltage across R19 is not sufficient, the amplifier output goes high and turns on transistor Q10. This action causes transistor Q9 to turn off and also causes the X-Y current generators to turn off in a manner similar to that described in Paragraph 2.2.1.

NOTE

If the G235 Driver Module is removed from the system unit, DRVA PWR OK L remains unasserted and transistor Q1 on the G114 Sense Inhibit Module prevents the inhibit drivers from being turned on.

2.3 OPERATING MODE SELECTION LOGIC

When the memory is addressed by the master device, one of four bus operations (DATI, DATIP, DATO, DATOB) is selected. The selection is determined by control bits C01 and C00 and address bit A00 which selects the high or low byte in a DATOB. These control signals are placed on the Unibus by the master device. Table 2-1 shows the state of these bits for each type of bus operation.

**Table 2-1
Selection of Bus Transaction**

Transaction	Mnemonic	Mode Control		Control A00	Function
		C(01:00)	Octal		
Data In	DATI	00	0	X	Data from memory to master. Memory performs read and restore operations.
Data In, Pause	DATIP	01	1	X	Data from memory to master. Restore operation is inhibited. Must be followed by DATO or DATOB which performs a write operation without the initial clear.
Data Out	DATO	10	2	X	Data from master to memory (words).
Data Out, High Byte	DATOB	11	3	1	Data from master to memory. High byte on data lines D(15:08).
Data Out, Low Byte	DATOB	11	3	0	Data from master to memory. Low byte on data lines D(07:00).

X = irrelevant

The logic that decodes the bus operation and byte selection is shown on M8293-0-1, sheet MATH. Bits BUS C01, BUS C00, and BUS A00 are supplied to three receivers from the Unibus. The receivers for BUS C00 and BUS C01 are located on sheet MATH and the receiver for BUS A00 is located on sheet MATF. The BUS C01 and BUS C00 signals are applied to a bistable latch and generate both polarities of MATH C0 and MATH C1. These signals are combined with MATF A00 and generate both polarities of MATH WRITE BYTE (0) and MATH WRITE BYTE (1). These signals in turn, are used to enable the following signals:

MATB	CLK	MDR	0	L
MATB	CLK	MDR	1	L
MATB	CLEAR	MDR	0	L
MATB	CLEAR	MDR	1	L
DRVA	SS0	L		
DRVA	SS1	L		

In addition, MATH C1 L is used to enable MATC OUTPUT ENABLE H. These signals are listed in Table 2-2 which tabulates the memory operating signals generated for each of the bus operations. To avoid confusion in interpreting the transactions listed in Table 2-2, the purpose of the PAUSE flip-flop is discussed briefly. During DATIP, the PAUSE flip-flop is set during the read operation which inhibits the restore (write) operation. The DATIP must be followed by a DATO or DATOB on the same address. The DATO or DATOB that follows a DATIP is shorter than a standard DATO or DATOB because the initial clear operation is eliminated. In Table 2-2, the suffix PAUSE L identifies the standard transactions; the suffix PAUSE H identifies the DATO and DATOB transactions that must follow a DATIP.

Table 2-2
Generation of Memory Operating Signals

Mode	Byte Control A00	Mode Control		State of PAUSE Flip-Flop	Signals Generated						Operational Sequence	
					DRVA SS0 L	DRVA SS1 L	MATB CLR MDR (0) L	MATB CLR MDR (1) L	MATB CLK MDR (0) L	MATB CLK MDR (1) L		MATC OUTPUT ENABLE H
		C01	C02									
DATI	X	0	0	Reset	✓	✓	✓	✓			✓	Read-restore.
DATIP	X	0	1	Reset-Set	✓	✓	✓	✓			✓	Read-pause. Restore inhibited by PAUSE flip-flop.
DATO PAUSE L	X	1	0	Reset					✓	✓		Clear-write
DATO PAUSE H	X	1	0	Set					✓	✓		Write. Must follow DATIP.
DATOB PAUSE L	0	1	1	Reset		✓		✓	✓			Clear-write selected byte 0. Read-restore nonselected byte 1.
DATOB PAUSE H	0	1	1	Set				✓	✓			Write selected byte 0. Restore non-selected byte 1. Must follow DATIP.
DATOB PAUSE L	1	1	1	Reset	✓		✓				✓	Clear-write selected byte 1. Read-restore nonselected byte 0.
DATOB PAUSE H	1	1	1	Set			✓				✓	Write selected byte 1. Restore non-selected byte 0. Must follow DATIP.

✓ = irrelevant

2.3.1 Operating Modes

2.3.1.1 Master Sync – In a bus operation, the master device always times the MSYN signal to ensure that MSYN does not reach the slave device prior to the time that the address and control lines on the Unibus have been decoded and are stabilized. Consequently, the bus receiver outputs for the address and control signals indicate the address and mode of the next bus cycle at least 75 ns before BUS MSYN L is received. This 75 ns delay is necessary to allow time for: a) device selection, b) address decoding, and c) mode selection.

2.3.1.2 Slave Synchronization (SSYN) Circuit – Slave synchronization (SSYN) is the response of the slave device to master synchronization (MSYN). The master places address information, mode control information, and data (if a DATO or DATOB is selected) on the Unibus. It then asserts BUS MSYN L only if BUS SSYN L from the previous slave device is cleared, which indicates that the bus transactions can be accomplished. The slave asserts BUS SSYN L when it has data to send (DATI or DATIP) or when it has received data (DATO or DATOB). The master receives BUS SSYN L in either case and clears BUS MSYN L.

When the slave receives the cleared BUS MSYN L, it clears BUS SSYN L, which frees the bus. This brief statement of the SSYN/MSYN interaction is necessary to understand the operation of the memory SSYN circuit. Details of the SSYN/MSYN interaction during all bus transactions can be found in the *PDP-11 Peripherals Handbook*.

2.3.1.3 Device Selection – In order to select the memory, the address lines BUS A17:A01 L must indicate one of the 16K word addresses starting at the minimum address selected by jumpers W7 through W3. The 7485 IC (E32) on M8293-0-1, sheet MATA, examines the received address and compares it with the minimum address configured by jumpers W7 through W3. This address is the initial address in a 16K bank. The output (pin 5) of E32 is asserted if the received address is equal to or greater than the address specified by the jumpers.

The output (pin 7) of the other 7485 IC (E29) is asserted if the received address is less than the jumper address plus 16K, which means that the address is in the specified bank. If both pin 5 of E32 and pin 7 of E29 are asserted, the device is selected and MATA BANK SEL L is asserted.

BANK SEL L will also be asserted if the starting address jumpers are cut for 112K, 116K, or 120K and pin 5 of start address comparator E32 is asserted. If interleaving is employed, BANK SEL L will be asserted if the starting address jumpers are cut for 96K or higher and pin 5 of E32 is asserted.

NOTE

BANK SEL L will always be inhibited for bus addresses between 124K and 128K. These addresses are reserved for hardware registers and peripheral devices.

2.3.1.4 Address Decoding – Bus address lines (A14:A01) are received by type 380 bus receivers (sheets MATE, F, and H). The outputs of these receivers feed 7475 quad latches. The outputs of the latches follow the inputs prior to receipt of BUS MSYN L. The outputs of the latches are applied to the 7442 and 74154 memory address decoders on the G235 Driver Module (sheets DRVB and DRVC). The decoders decode three or four inputs to 8 or 16 mutually exclusive outputs to decode the address as shown below.

- a. Bits A14, A06, A05 and A03 are applied to a 74154 decoder (E28) to select one pair of Y read/write switches (Figure 2-4).
- b. Bits A04, A02 and A01 are applied to a 7442 decoder (E19) to select one pair of Y read/write drivers.
- c. Bits A13, A12, A11 and A10 are applied to a 74154 decoder (E27) to select one pair of X read/write switches.
- d. Bits A09, A08 and A07 are applied to a 7442 decoder (E32) to select one pair of X read/write drivers.

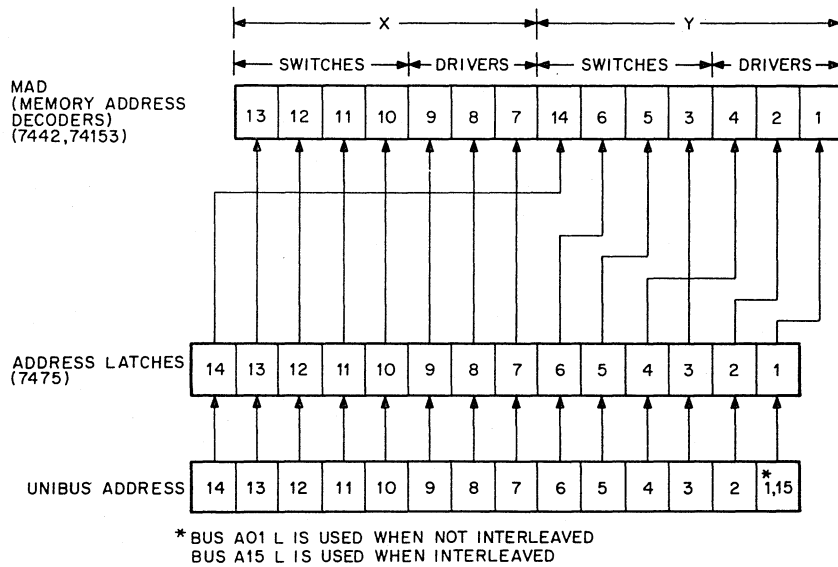

Figure 2-4 Switch and Driver Selection

Selection of the appropriate X and Y read/write drivers is accomplished prior to the receipt of BUS MSYN L. The switches and drivers are not turned on, however, until a timing cycle is initiated by BUS MSYN L and MATA BANK SEL H (Paragraph 2.5.2).

2.3.1.5 Mode Selection – The operating mode is determined by BUS C0 L and BUS C1 L. The four operating modes are:

Mode	BUS C0 L	BUS C1 L	Description
DATI	H	H	Read–restore
DATIP	L	H	Read–pause
DATO	H	L	Clear write
DATOB	L	L	Clear (byte)–write (byte)

The DATOB cycle refers to byte operation and performs a clear/write cycle on the byte indicated by BUS A00 L and a read–restore cycle on the other byte.

The C0, C1, and A0 signals are treated similar to the address signals (received and stored in 7475 latches). The byte masking logic (on MATH) uses the C00, C01, and A00 signals to generate both polarities of MATH WRITE BYTE 0 and MATH WRITE BYTE 1. These signals are used to indicate whether a clear–write operation or a read–restore operation is to be performed on the respective bytes.

Figure 2-5 shows the timing for the DATI mode, Figure 2-6 shows the timing for the DATIP mode, and Figure 2-7 shows the timing for the DATO or DATOB mode. These timing diagrams, in conjunction with the overall flow diagram of the 16K Unibus timing module and the detailed flows, should provide the reader with the necessary information to understand and repair the timing module.

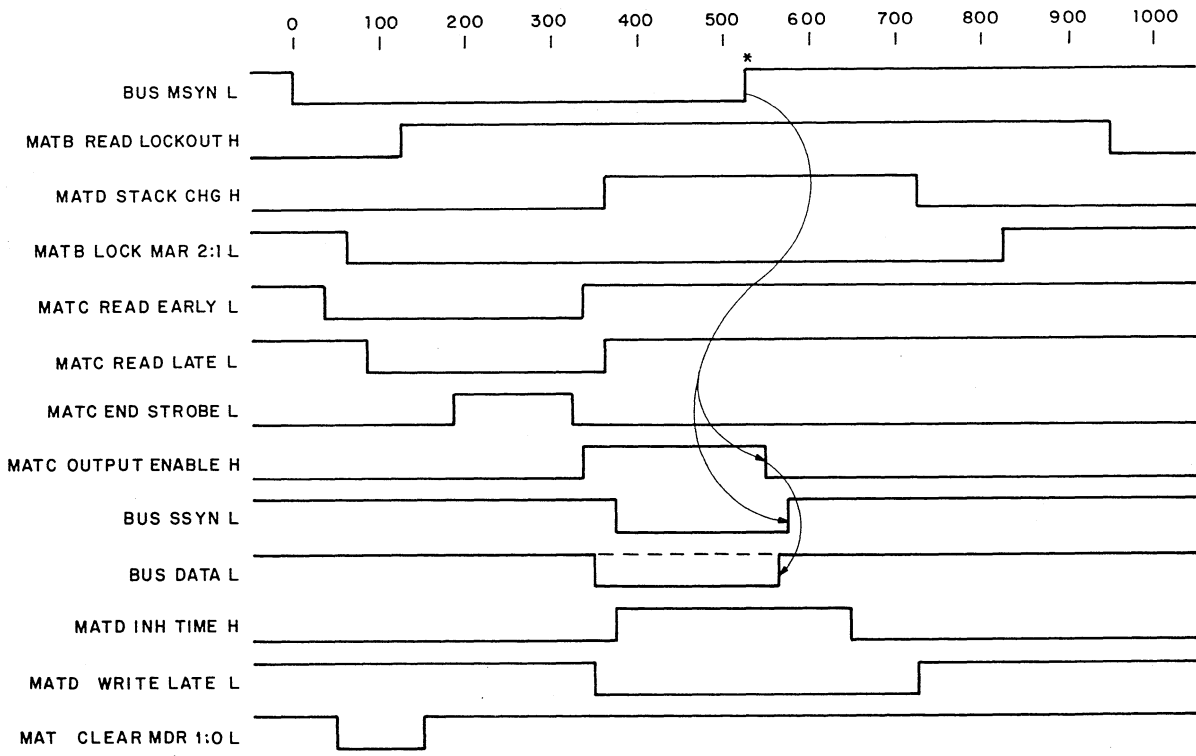

NOTE: * Actual time depends on bus and processor delays.
 DATI
 BUS C0 = H
 BUS C1 = H

11-1777

Figure 2-5 DATI Mode Timing Diagram

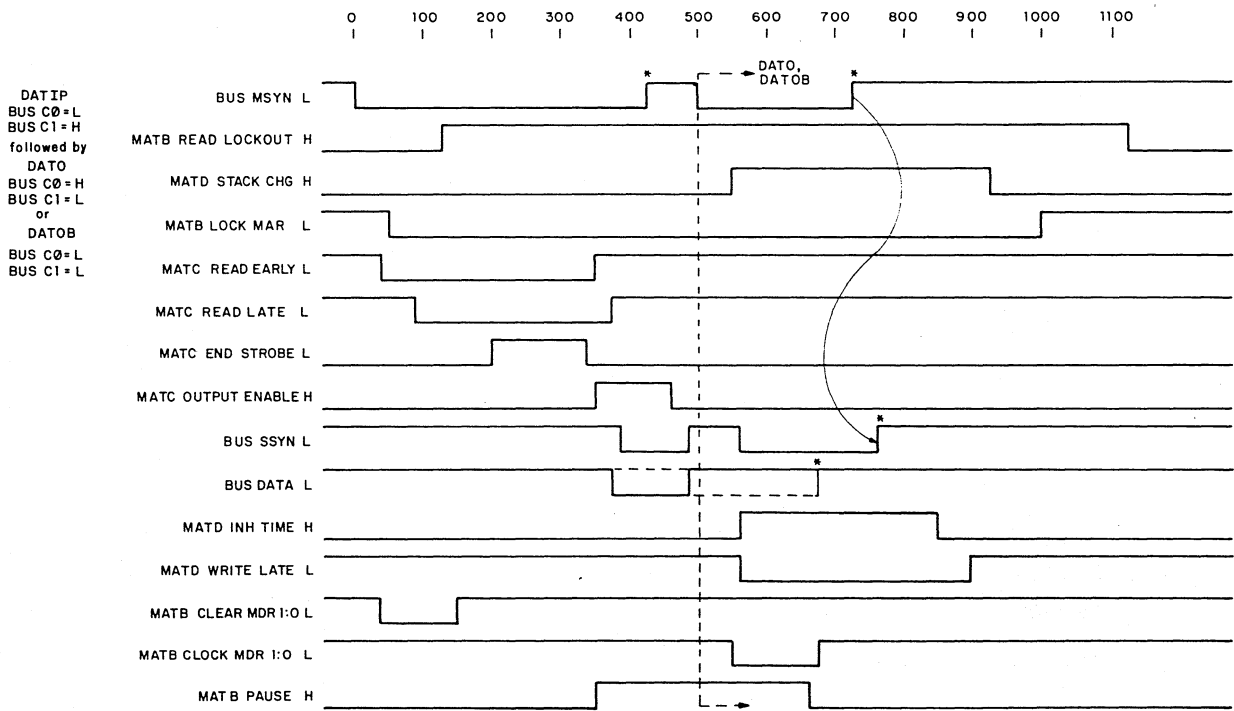

NOTE: * Actual time depends on bus and processor delays.

11-1778

Figure 2-6 DATIP Mode Timing Diagram

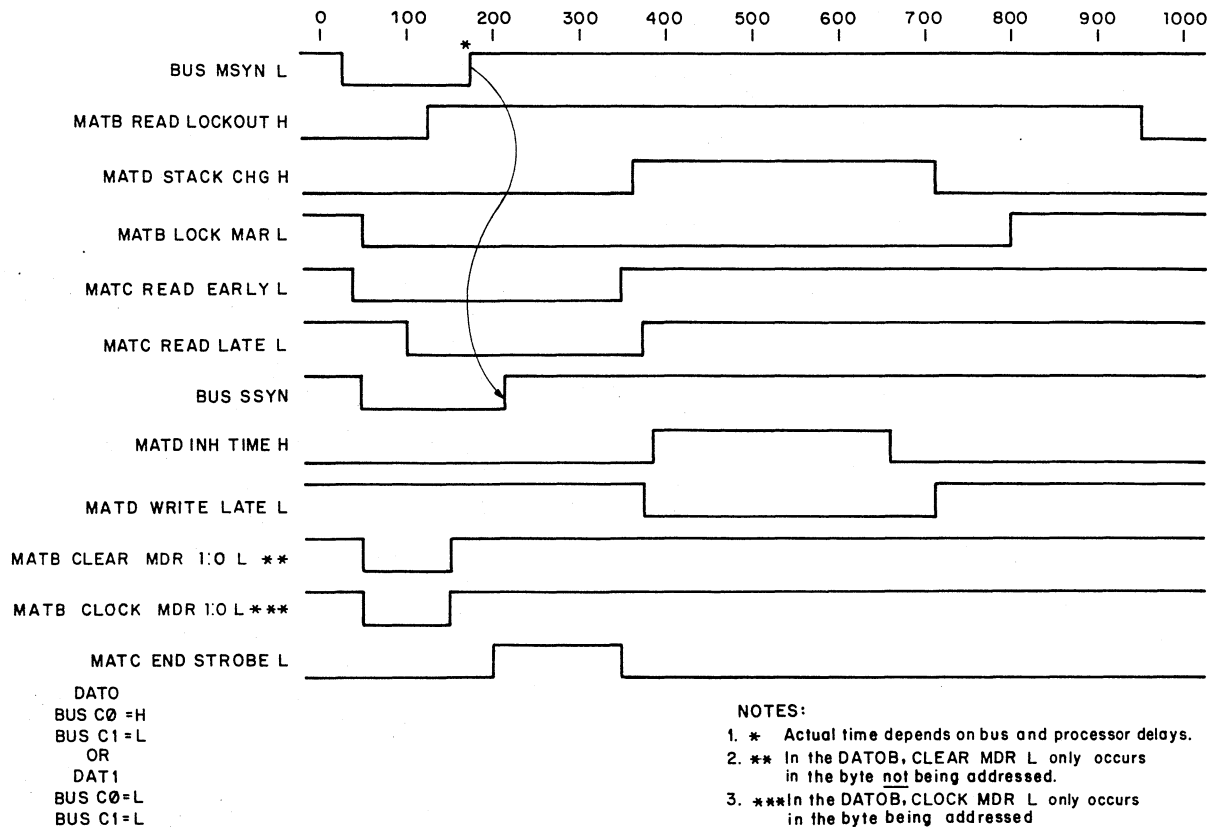

11-1779

Figure 2-7 DATO, DATOB Mode Timing Diagram

2.3.1.6 DATI MODE (Read-Restore) – In this mode, MATH WRITE BYTE 0 H and MATH WRITE BYTE 1 H are not asserted. BUS MSYN L is asserted by the processor or master and generates MATB MSYN H. If the READ LOCKOUT flip-flop is not set and MATA BANK SEL H is asserted, MATB A EARLY L is asserted. This signal is applied to the driver module (G235-0-1, sheet 4) to start Y read current flowing.

In addition, MATB MSYN L is applied to the delay line driver gating (E11 on sheet MATB) and will start a voltage pulse down DL2 if the following conditions are met:

- a. MATJ MSYN HOLDOFF H is not asserted (indicating that neither BUS INIT L nor BUS DC LO L is asserted).
- b. MATA BANK SEL L is asserted.
- c. MATB READ LOCKOUT H is not asserted.

The voltage pulse going down the delay line will first assert MATB START READ H which does the following:

- a. Latches the delay line driver gating on so that the only thing which will turn off the voltage applied to the delay line is the assertion of MATB READ LOCKOUT H.
- b. Causes MATB CLEAR MDR 0 L and MATB CLEAR MDR 1 L to be asserted (clears the data register so that new data read from memory can be stored).

- c. Causes MATB LOCK MAR 2 L and MATB LOCK MAR 1 L to be asserted (this sets the LOCK MAR flip-flop) which locks the address and control latch outputs to their latest state.
- d. Causes the END WRITE flip-flop (on MATD) to be reset (this flip-flop was set by the previous cycle). Since MATC SSYN L is now unasserted this allows MATD END OF WRITE L to be unasserted – thus enabling the READ and WRITE LOCKOUT flip-flops to be set at the appropriate times.
- e. Causes MATD MSYN STILL LO L to be asserted. This signal stays asserted until BUS MSYN L goes unasserted.
- f. Sets the READ EARLY flip-flop.
- g. 50 NS DELAY LINE TAP – sets the READ LATE flip-flop.
- h. 75 NS DELAY LINE TAP – sets the READ LOCKOUT flip-flop which turns off the input to the delay line and hence determines the width of the pulse traveling down the delay line.
- i. 150 NS DELAY LINE TAP – sets END STROBE flip-flop.
- j. 250 NS DELAY LINE TAP – feeds the output of DL2 to the input of DL1.
- k. 300 NS DELAY LINE TAP – resets END STROBE flip-flop. Sets the OUTPUT ENABLE flip-flop allowing data to be gated onto the Unibus. (This flip-flop is reset when BUS MSYN L is cleared.) Resets READ EARLY flip-flop. Starts the restore cycle by turning on the write delay line driver. (This starts a voltage pulse down DL4.)
- l. 325 NS DELAY LINE TAP – resets READ LATE flip-flop. Causes BUS SSYN to be asserted. (The SSYN flip-flop is reset when BUS MSYN L is cleared.)
- m. WRITE 0 DLY H – sets the STACK CHARGE flip-flop which generates MATD WRITE EARLY L. Latches the write delay line driver gating so that only the WRITE LOCKOUT flip-flop can terminate the voltage pulse applied to DL4.
- n. WRITE 25 NS DELAY LINE TAP – sets INHIBIT TIMING flip-flop. Sets WRITE LATE flip-flop.
- o. WRITE 125 NS DELAY LINE TAP – sets the WRITE LOCKOUT flip-flop, terminating the voltage pulse traveling down DL4.
- p. WRITE 325 NS DELAY LINE TAP – resets INHIBIT TIMING flip-flop.
- q. WRITE 375 NS DELAY LINE TAP – resets STACK CHARGE flip-flop which causes MATD WRITE EARLY L to be unasserted.
- r. WRITE 400 NS DELAY LINE TAP – clears the WRITE LATE flip-flop.
- s. WRITE 450 NS DELAY LINE TAP – resets the LOCK MAR flip-flop, allowing the latch outputs to once more follow the inputs. When the trailing edge of the voltage pulse has passed this tap and is still present at the end of the delay line, the END WRITE flip-flop is set.

When MATC SSYN L is unasserted, MATD END OF WRITE L is asserted, causing the READ and WRITE LOCKOUT flip-flops to reset. This allows a new memory cycle to be initiated upon receipt of a new BUS MSYN L signal.

2.3.1.7 DATIP Mode – The DATIP mode is the same as the DATI mode except that the 300 ns delay line tap sets the PAUSE flip-flop instead of causing a voltage pulse to start down the write delay lines. A DATO or DATOB to this memory must follow the DATIP cycle before any other bus cycles.

2.3.1.8 DATO (Clear–Write) – The DATO cycle not preceded by a DATIP cycle (PAUSE flip-flop not set) is the same as the DATI cycle with the following exceptions:

- a. MATH WRITE BYTE 0 AND MATH WRITE BYTE 1 are both asserted.
- b. MATB CLK MDR 0 L and MATB CLK MDR 1 L are asserted instead of MATB CLEAR MDR 0 L and MATB CLEAR MDR 1 L. The clock signals are generated by the assertion of MATH WRITE BYTE 0 and MATH WRITE BYTE 1 and allow the data to be clocked from the Unibus into the data register.
- c. BUS SSYN L is asserted by MATB CLOCK MDR 0 L or MATB CLOCK MDR 1 L. The SSYN flip-flop is reset when BUS MSYN L is cleared.

2.3.1.9 DATO – The DATO cycle preceded by a DATIP cycle (PAUSE flip-flop set) is similar to the DATI cycle with the following exceptions:

- a. When MATB MSYN H is generated it does not start a pulse down the read delay line since the READ LOCKOUT flip-flop is set.
- b. As a result of PAUSE being set, MATB CLK MDR 0 L and MATB CLK MDR 1 L are generated to clock the new bus data into the data register. This also causes BUS SSYN L to be asserted. This signal will drop when BUS MSYN L drops.
- c. A voltage pulse is sent down the write delay lines causing the same sequence of events as the write portion of a DATI cycle. This portion of the cycle is initiated by the 300 ns delay line tap in a DATI mode.

2.3.1.10 DATOB Mode – The DATOB mode is the same as the DATO mode except that A00 indicates the byte selected for the write operation. A read–restore cycle is performed on the non-selected byte. The byte masking logic on sheet MAT.1 WRITE BYTE 0 H or MATH WRITE BYTE 1 H depending on the value of A00.

2.4 DEVICE AND WORD SELECTION

2.4.1 Introduction

When the processor or a peripheral device desires to perform a transaction with the memory, the processor asserts an 18-bit address on Unibus address lines A(17:00). Fourteen bits A(14:01) indicate the address of a specific word within the memory. Address bit A00 is used to select the byte (8 bits) transaction when in the DATOB mode.

The memory address is decoded by the device selection circuit on the M8293 16K Unibus Timing Module. The word address is stored in a register on this module whose output is decoded to activate the X–Y line switches and drivers that select the addressed word. These circuits contain jumpers that are included or excluded to configure the memory as follows: establish a specific device address; and select interleaved or non-interleaved operation. The device address is a 16K bank, starting on any 4K increment selected by the five device select jumpers.

Table 2-3 lists the function of the address bits (Figure 2-4).

Table 2-3
Addressing Functions

Bus Address	Function
A00	Controls Byte Mode
A01	Non-Interleaved Mode: becomes A01H to M8293 Interleaved Mode: goes to Device Selector
A02, A04, A01H*	Decode Y Drivers
A03, A05, A06, A14	Decode Y Switches
A07, A08, A09	Decode X Drivers
A10, A11, A12, A13	Decode X Switches
A15	Goes to Device Selector Interleaved Mode: becomes A01H to M8293
A13, A14, A16, A17	Goes to Device Selector

*A01H is not a Unibus signal

2.4.2 Memory Organization and Addressing Conventions

Prior to a detailed discussion of the address selection logic, it is desirable to understand memory organization and addressing conventions.

The memory is organized in 16-bit words, each consisting of two 8-bit bytes. The bytes are identified as low and high as shown below.

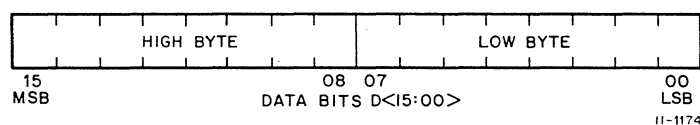

Each byte is addressable and has its own address location; low bytes are even numbered and high bytes are odd numbered. Words are addressed at even-numbered locations only; the high (odd) byte is automatically included.

For example, a 16K word memory has 16,384 words or 32,768 bytes; therefore, 32,768 locations are assigned. The address locations are specified as 6-digit octal numbers. The 32,768 locations are designated 000000 through 077777 as shown in Figure 2-8.

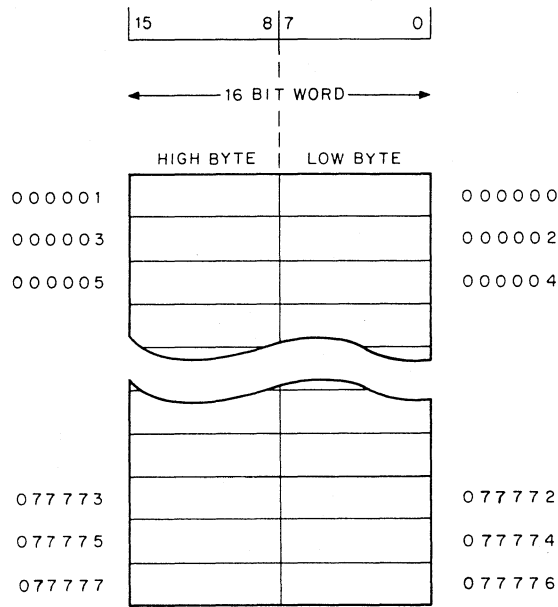

11-1789

Figure 2-8 Memory Organization

The address selection logic responds to the binary equivalent of the octal address. The binary equivalent of 017772 is shown below as an example.

ADDRESS BITS A<17:00>																		
17	16	15	14	13	12	11	10	09	08	07	06	05	04	03	02	01	00	BIT POSITION
0	0	0	0	0	1	1	1	1	1	1	1	1	1	1	0	1	0	BINARY
0			1			7			7			7			2			OCTAL

11-1173

Each memory bank requires its own unique device address. For example, assume that a system contains three 16K memory banks as shown in Figure 2-9. The device selector for the 16K non-interleaved memory decodes five address lines [A(17:13)]. Examination of the binary states of these lines for the three memory banks shows that the changes in the states of bits A15 and A16 allow the selection of a unique combination for each bank. The combination, which is the device address, is hardware selected by jumpers in the device selector.

2.4.3 Device Selector

The device selector is located on the 16K Unibus timing module. Address bits A01 and A(17:13) are decoded in the device selector to provide the device selection signal MATA BANK SEL L that is used in the control logic. Two combinations of these bits are decoded depending on the memory configuration as shown below.

Memory Configuration	Address Bit
16K Words (non-interleaved)	A(17:13)
16K Words (interleaved)	A01, A(17:13)

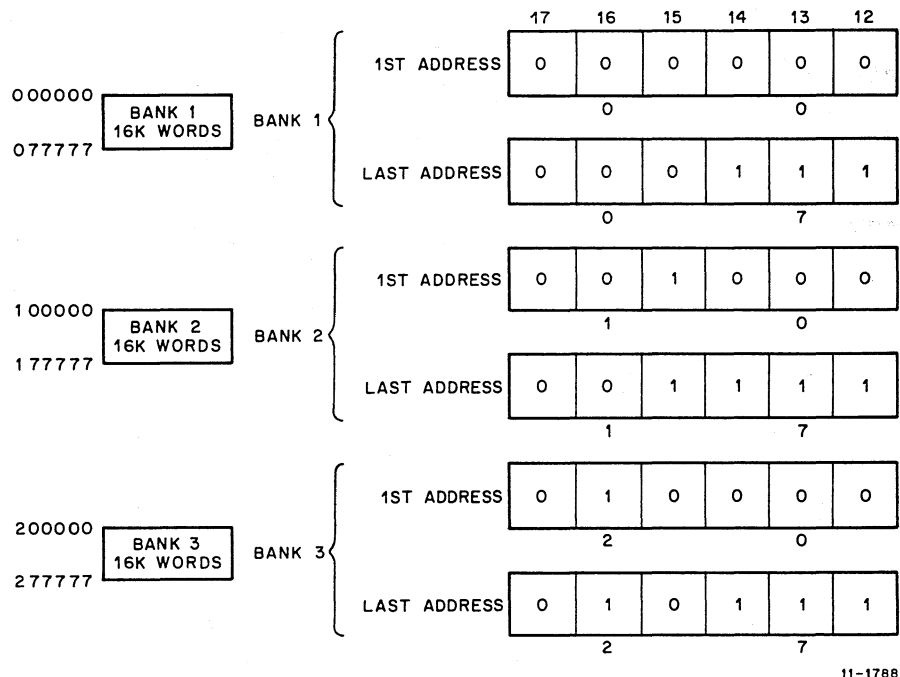

Figure 2-9 Address Assignments for Three Banks Of 16K Words Each

Five jumpers (W1, W2, W8, W9, and W10) in the device selection logic on the control module are used to control interleaved or non-interleaved operation of the 16K memory. For non-interleaved operation W1 is in and W2, W8, W9, and W10 are out. Table 2-4 shows the jumper configuration for non-interleaved memory addresses up to 124K.

Each memory bank must have its own unique device address field. Five jumpers (W3, 4, 5, 6, and 7) in the device selector provide this capability. In drawing M8293-0-1, sheet 2, all the jumpers are shown in place and the device selector would respond only when high signals appear on the Unibus address lines A(17:13). Some jumpers can be removed to allow the device selector to respond to a particular combination of high and low signals on these address lines.

All highs at the inputs of the 380 Unibus receivers give lows at their outputs. Each receiver output goes to two comparators; one to determine if the bus address is above the minimum address of the field and one to determine if the bus address is below the maximum address of the field (M8293-0-1, sheet MATA).

The other inputs of the 7485 gates associated with bits A(17:13) can be connected to +5 V or ground, depending on whether or not jumpers W3 through W7 are installed. The input is low (ground) with the jumper in; and input is high (+5 V) with the jumper removed.

To configure the jumpers for a specific device address, find the binary equivalent of the assigned octal starting address and insert a jumper in each bit position that contains a 0.

Table 2-4
Device Address Jumpers (Non-Interleaved)

Memory Bank (Words)	Machine Address (Words) ₈	W3 A17	W4 A16	W5 A15	W6 A14	W7 A13
0-16K	000000-077776	IN	IN	IN	IN	IN
4-20K	020000-117776	IN	IN	IN	IN	OUT
8-24K	040000-137776	IN	IN	IN	OUT	IN
12-28K	060000-157776	IN	IN	IN	OUT	OUT
16-32K	100000-177776	IN	IN	OUT	IN	IN
20-36K	120000-217776	IN	IN	OUT	IN	OUT
24-40K	140000-237776	IN	IN	OUT	OUT	IN
28-44K	160000-257776	IN	IN	OUT	OUT	OUT
32-48K	200000-277776	IN	OUT	IN	IN	IN
36-52K	220000-317776	IN	OUT	IN	IN	OUT
40-56K	240000-337776	IN	OUT	IN	OUT	IN
44-60K	260000-357776	IN	OUT	IN	OUT	OUT
48-64K	300000-377776	IN	OUT	OUT	IN	IN
52-68K	320000-417776	IN	OUT	OUT	IN	OUT
56-72K	340000-437776	IN	OUT	OUT	OUT	IN
60-76K	360000-457776	IN	OUT	OUT	OUT	OUT
64-80K	400000-477776	OUT	IN	IN	IN	IN
68-84K	420000-517776	OUT	IN	IN	IN	OUT
72-88K	440000-537776	OUT	IN	IN	OUT	IN
76-92K	460000-557776	OUT	IN	IN	OUT	OUT
80-96K	500000-577776	OUT	IN	OUT	IN	IN
84-100K	520000-617776	OUT	IN	OUT	IN	OUT
88-104K	540000-637776	OUT	IN	OUT	OUT	IN
92-108K	560000-657776	OUT	IN	OUT	OUT	OUT
96-112K	600000-677776	OUT	OUT	IN	IN	IN
100-116K	620000-717776	OUT	OUT	IN	IN	OUT
104-120K	640000-737776	OUT	OUT	IN	OUT	IN
108-124K	660000-757776	OUT	OUT	IN	OUT	OUT
112-124K	700000-757776	OUT	OUT	OUT	IN	IN
116-124K	720000-757776	OUT	OUT	OUT	IN	OUT
120-124K	740000-757776	OUT	OUT	OUT	OUT	IN

NOTE: The memory may be interleaved in 32K increments, using two contiguously addressed 16K banks.

In the 16K interleaved memory configuration the following changes must be made:

W1 is cut	
W2 is in	
W8 is in	
W9 is in	} For one 16K of the interleaved pair
W10 is cut	
W9 is cut	} For the other 16K of the interleaved pair
W10 is in	

Both interleaved memories should be cut for the same starting address.

Table 2-5 shows the jumper configuration for interleaved memory addresses up to 124K. When interleaving, two contiguously addressed 16K memory banks must be interleaved.

Table 2-5
Device Address Jumpers (Interleaved)

Memory Bank (Words)	Machine Address (Words) ₈	W3 A17	W4 A16	W5 A15	W6 A14	W7 A13
0-32K	000000-177776	IN	IN	IN	IN	IN
4-36K	020000-217776	IN	IN	IN	IN	OUT
8-40K	040000-237776	IN	IN	IN	OUT	IN
12-44K	060000-257776	IN	IN	IN	OUT	OUT
16-48K	100000-277776	IN	IN	OUT	IN	IN
20-52K	120000-317776	IN	IN	OUT	IN	OUT
24-56K	140000-337776	IN	IN	OUT	OUT	IN
28-60K	160000-357776	IN	IN	OUT	OUT	OUT
32-64K	200000-377776	IN	OUT	IN	IN	IN
36-68K	220000-417776	IN	OUT	IN	IN	OUT
40-72K	240000-437776	IN	OUT	IN	OUT	IN
44-76K	260000-457776	IN	OUT	IN	OUT	OUT
48-80K	300000-477776	IN	OUT	OUT	IN	IN
52-84K	320000-517776	IN	OUT	OUT	IN	OUT
56-88K	340000-537776	IN	OUT	OUT	OUT	IN
60-92K	360000-557776	IN	OUT	OUT	OUT	OUT
64-96K	400000-577776	OUT	IN	IN	IN	IN
68-100K	420000-617776	OUT	IN	IN	IN	OUT
72-104K	440000-637776	OUT	IN	IN	OUT	IN
76-108K	460000-657776	OUT	IN	IN	OUT	OUT
80-112K	500000-677776	OUT	IN	OUT	IN	IN
84-116K	520000-717776	OUT	IN	OUT	IN	OUT
88-120K	540000-737776	OUT	IN	OUT	OUT	IN
92-124K	560000-757776	OUT	IN	OUT	OUT	OUT
96-124K	600000-757776	OUT	OUT	IN	IN	IN
100-124K	620000-757776	OUT	OUT	IN	IN	OUT
104-124K	640000-757776	OUT	OUT	IN	OUT	IN
108-124K	660000-757776	OUT	OUT	IN	OUT	OUT
112-124K	700000-757776	OUT	OUT	OUT	IN	IN
116-124K	720000-757776	OUT	OUT	OUT	IN	OUT
120-124K	740000-757776	OUT	OUT	OUT	OUT	IN

NOTE: If interleaving is desired, the memory must be interleaved in 32K increments, using two contiguously addressed 16K banks.

2.4.4 Word Selection

Word selection requires two levels of decoding. The word address bits are placed in the 14-bit word address register. Outputs from the register are used as inputs to a group of decoders (Figure 2-10). The outputs of the decoders select the proper X and Y read/write switches and drivers.

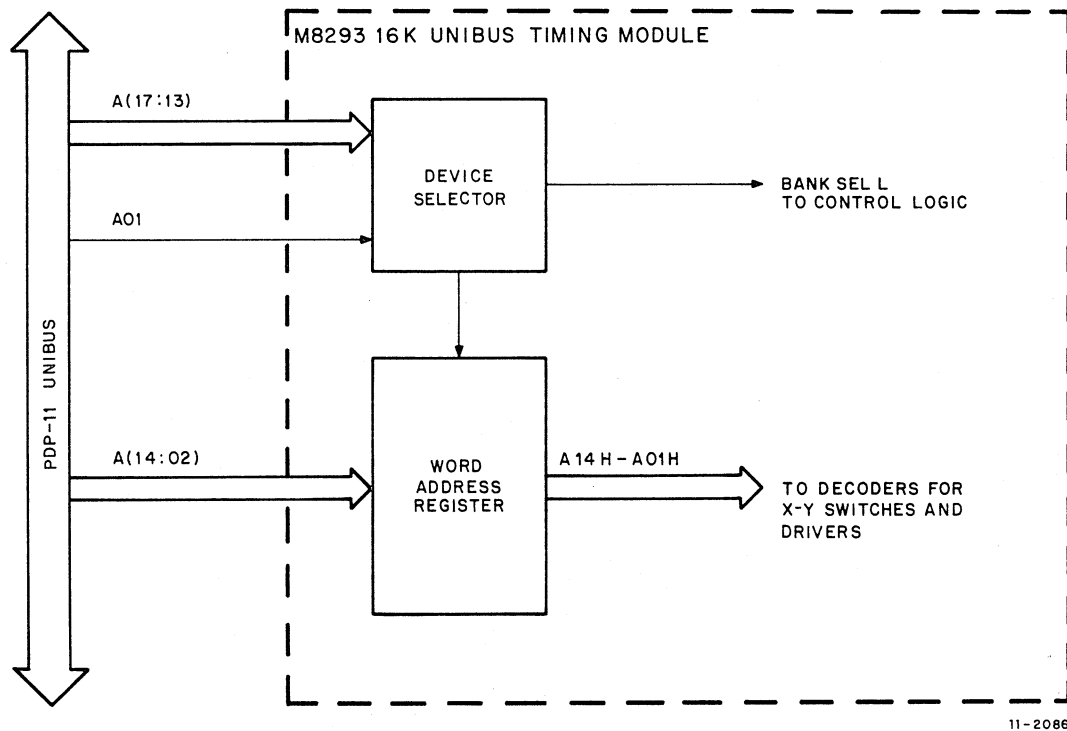

Figure 2-10 Device and Word Address Selection Logic Block Diagram

2.4.4.1 Word Address Register – The word address register is contained on the 16K Unibus timing module. The circuit schematic is shown in drawing M8293-0-1. The register is composed of 4 quad 7475 D-Type latches. They are identified as E16, E20, E24, and E36. The word address register cannot be directly cleared or preset; its output responds only to the signal at its D (data) input. Address bits A(14:02) are picked off the Unibus via type 380 quad receivers. The receiver outputs are applied to the corresponding latch inputs. The latch associated with bit A01 receives its input from the device selector (drawing M8293-0-1). The input signal is MATA LEAST BIT H, which is obtained from bit A01 Unibus receiver for a 16K non-interleaved memory. For a 16K interleaved memory, MATA LEAST BIT H is obtained from bit A15 Unibus receiver.

The register latches are locked by MATB LOCK MAR 1 L and MATB LOCK MAR 2 L from the control logic (drawing M8293-0-1, sheet MATB). The generation and timing of this lock signal is discussed in Paragraph 2.5.2. The outputs of the latches are sent to the 7442 and 74154 X–Y line decoders on the driver module (G235-0-1, sheets 4 and 5).

Prior to the generation of the MATB LOCK MAR 1 L and MATB LOCK MAR 2 L, the address lines at the outputs of the latches follow the state of the bus receiver outputs. In this way, the decoder outputs (E19, 27, 28, and 32 on the G235 Driver Module) indicate the selected address slightly before BUS MSYN is received. Hence, the X and Y drivers on the G235 module (G235-0-1, sheets 4 and 5) are turned on after receipt of BUS MSYN.

2.5 CONTROL LOGIC

2.5.1 Introduction

The control logic generates the precisely timed signals that initiate, control, and stop the memory operations that are requested as a result of the decoding of the bus transaction. The heart of the control logic is the delay line timing circuit (M8293-0-1, sheet MATB). For better understanding, the read and write memory sequences are described separately with associated timing diagrams. The discussion is to detailed logic level but the signals are not traced through each component. The text is referenced to logic drawing M8293-0-1.

2.5.2 Timing Circuit

The heart of the memory control logic is the timing circuit. When activated, it generates a series of precisely timed signals that control memory operation. The major components of the timing circuit are delay lines (DL1 to DL4) with multiple 25-ns taps (drawing M8293-0-1). The delay line outputs set and reset flip-flops to produce the control signals shown in Figures 2-11 and 2-12.

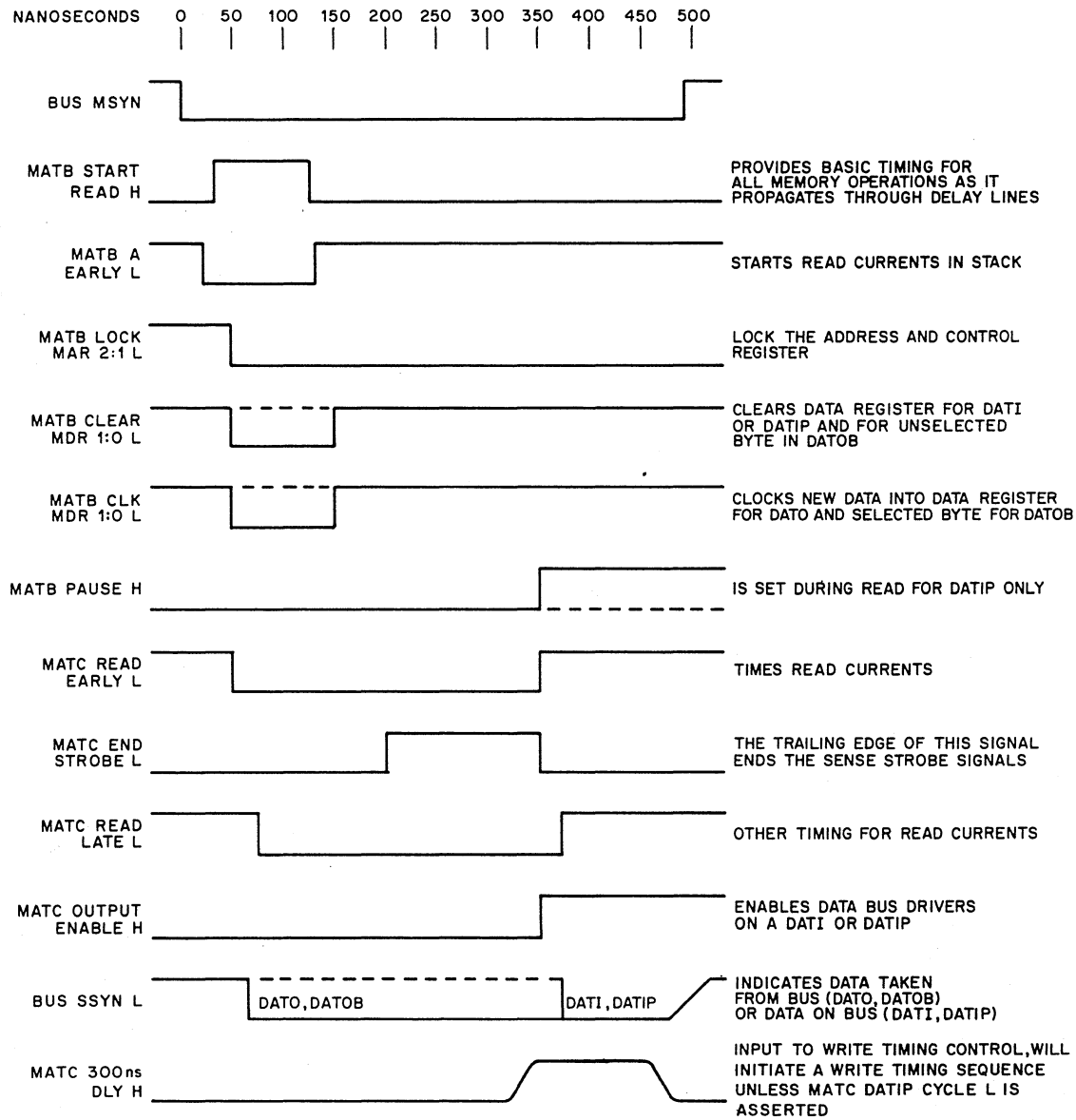

11-1748

Figure 2-11 Read Timing Sequence

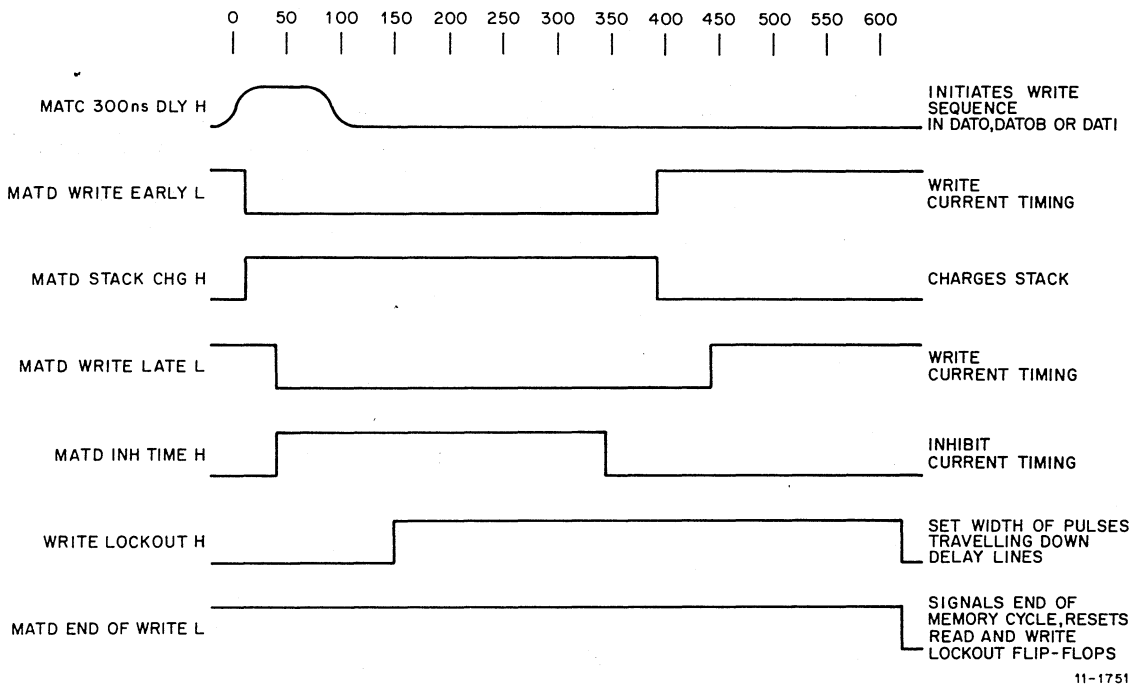

Figure 2-12 Write Timing Sequence

When the system is turned on the processor asserts BUS INIT L on the Unibus. This initializing signal is received and eventually asserts MATJ IZ L and MATJ IZ H as discussed in Paragraph 2.2.1. MATJ IZ L and MATJ IZ H initialize all required flip-flops in the memory and when BUS INIT L is removed, the memory is ready to accept address, control, and data. When the processor asserts BUS MSYN L a memory cycle is begun (provided the memory is not busy as indicated by MATB READ LOCKOUT H, provided the address is within the device selection limits as indicated by MATA BANK SEL L, and provided DC LO L or BUS INIT L is not asserted). AND-OR-INVERT gate E11 (sheet MATB, zone B-7) on the M8293 module determines if a memory cycle is to occur when BUS MSYN L is received. The output of E11 (Pin 8) is buffered by transistor Q3 which drives a tapped delay line DL2. The pulse width of the signal applied to the delay line is determined by setting the READ LOCKOUT flip-flop at the 75 ns tap of the delay line. Hence, an approximately 100 ns wide positive pulse travels down the 250 ns (tapped every 25 ns) delay line DL2, and then into an identical delay line DL1 (sheet MATC). The leading edge of this pulse traveling down delay lines DL2 and DL1 first sets and then resets flip-flops, generating the timing pulses shown in Figure 2-11 (read cycle). A similar pair of delay lines (DL4 and DL3 – sheet MATD) are used to generate the timing and control signals shown in Figure 2-12 (write cycle). These timing signals are briefly described in the following paragraphs.

2.5.3 MATB START READ H Signal

This is the buffered output of transistor Q3 (zone B-6) and is the input to the read delay line DL2. MATB START READ H is 100 ns wide and occurs at the beginning of every read or clear operation. All operations from the bus (except a DATO or DATOB after a DATIP) cause this signal to be asserted.

2.5.4 MATB A EARLY L Signal

The combination of MATA BANK SEL H, MATB MSYN H, and the fact that the memory is not busy causes MATB A EARLY L to be asserted. This is advance timing to inform the G235 Driver Module to turn on the Y read current generator, Y read driver, Y read switch, X read current generator and X read switch. The X read driver is not turned on at this time and waits for MATB READ LATE L. MATB A EARLY L is only 100 ns wide, but is closely followed by MATC READ EARLY L which is ORed with MATB A EARLY L on the G235 Driver Module.

2.5.5 MATB LOCK MAR 1 L, MATB LOCK MAR 2 L Signals

These signals are asserted when MATB START READ L is asserted. MATB START READ L sets the LOCK MAR flip-flop. This flip-flop is reset near the end of the write cycle by MATD 450 NS DLY L. At this time, the address is no longer needed. When not asserted, the MATB LOCK MAR 1 L and MATB LOCK MAR 2 L signals allow the output of the address latches to follow the inputs to the latches from the bus receivers. The address latches are located on sheets MATE, MATF, and MATH. The outputs of the address latches are fed to the G235 Driver Module where they are decoded prior to the receipt of BUS MSYN L. When MATB LOCK MAR 1 L and MATB LOCK MAR 2 L are asserted, the address latches are locked in their present states and cannot follow the outputs from the bus receivers until the signals go unasserted.

2.5.6 MATB CLEAR MDR 0 L, MATB CLEAR MDR 1 L Signals

MATB CLEAR MDR 0 L clears the data register for the low byte (byte 0) immediately preceding the generation of SINA SENSE STROBE 0 H on the G114 Sense Inhibit Module. SINA SENSE STROBE 0 H is associated with reading in a DATI, DATIP, or is associated with the unselected byte of a DATOB. In a DATOB, a read-restore cycle is performed on the unselected byte and a clear-write is performed on the selected byte. MATB CLEAR MDR 1 L performs a similar operation for the high byte (byte 1). Both signals are enabled by MATB START READ H. If MATH WRITE BYTE 1 L is enabled, MATB CLEAR MDR 1 L is generated.

2.5.7 MATB CLK MDR 0 L, MATB CLK MDR 1 L Signals

MATB CLK MDR 0 L transfers the bus data receiver outputs into the memory data register associated with byte 0. MATB CLK MDR 1 L transfers the bus data receiver outputs into the memory data register associated with byte 1. The transfer takes place at the beginning of a DATO or DATOB (from the selected byte only), regardless of the state of the PAUSE flip-flop. MATD MSYN STILL LO L prevents the data register from being clocked at the end of a DATIP cycle. When this signal is asserted and PAUSE is set, it means that the BUS MSYN L signal from the Unibus is the MSYN due to the DATIP and has not been removed by the processor.

When MSYN L is released by the processor, MATD MSYN STILL LO L goes unasserted. When the next BUS MSYN L is received (with the PAUSE flip-flop set), the data register can be clocked, for it is known to be the correct MSYN signal. After the DATIP operation, the address and control latches are left in a locked state. Since a DATO or DATOB cycle must follow the DATIP, it is necessary for MATH WRITE BYTE 0 H and MATH WRITE BYTE 1 H to reflect the new control signals (C00, C01, and A00) rather than the signals locked in the latches at the beginning of the DATIP. Consequently, when the PAUSE flip-flop is set MATB PAUSE H allows the outputs of the bus receivers (sheet MATH) to designate the type of bus operation and the high or low byte. The outputs of the bus receivers accomplish this by modifying MATH WRITE BYTE 0 H and MATH WRITE BYTE 1 H. If PAUSE is not asserted, the outputs of the address and control latches determine the type of bus operation.

2.5.8 MATB PAUSE H Signal

When MATB PAUSE H is asserted, a DATO or DATOB operation is performed in about 2/3 the time normally required. This savings in time results from the fact that the clear operation has already been performed in the DATIP portion of the cycle, and does not have to be repeated for the DATO or DATOB. MATB PAUSE H also allows MATB MSYN H to start the write sequence timing chain. This signal is generated during a DATIP operation by MATC 300 NS DLY H and is reset by MATD 125 NS DLY L from the write sequence timing.

2.5.9 MATC READ EARLY L Signal

MATC READ EARLY L and MATB A EARLY L are ORed together. MATB A EARLY L, when asserted, turns on the X and Y switches, Y drivers, and the X and Y current generators. The X drivers are not yet turned on as these drivers are what actually switch the cores. MATB A EARLY L is generated prior to MATC READ EARLY L and turns on the appropriate switches, drivers and current generators prior to READ EARLY L time. The reason for this is to allow the transients to occur as long as possible before the cores are switched. When MATC READ EARLY L is unasserted, it turns off the X and Y current generators and the X and Y read drivers.

2.5.10 MATC END STROBE L Signal

MATC END STROBE L controls the trailing edge of the strobe signal, (SINA SENSE STROBE 0 H, SINA SENSE STROBE 1 H – G114-0-1, sheet 3), applied to the sense amplifiers. The leading edge of the strobe signal is variable and is determined by a one-shot (G235-0-1, sheet 6) which is triggered by DRVC X READ SINK TIME L. The one-shot time delay is controlled by Q14 which may be altered by STROBE MARGIN.

This signal is varied by either grounding AV1 (STROBE MARGIN) on the G235 module or connecting it to +5 V. This moves the leading edge of SINA SENSE STROBE and SINA SENSE STROBE 1, but does not affect the trailing edge. The sense strobe signals are wide in the MM11-U Memory to allow additional time for the core outputs to be propagated along the extremely long sense lines and to propagate through the associated signal path delays.

2.5.11 MATC READ LATE L Signal

MATC READ LATE L, when asserted, turns on the read X drivers which cause the read X current to start flowing. When the signal goes unasserted, the X and Y read switches are turned off.

2.5.12 MATC OUTPUT ENABLE H Signal

MATC OUTPUT ENABLE H allows the bus drivers located on the G114 module to apply the output data to the UNIBUS on a DATI or DATIP operation. MATC OUTPUT ENABLE H is generated at the same time SENSE STROBE is ended and becomes unasserted when BUS MSYN L becomes unasserted. The OUTPUT ENABLE flip-flop may also be reset by PCL MSYN DISABLE L (not presently utilized).

2.5.13 BUS SSYN L Signal

During a DATO or DATOB, BUS SSYN L is asserted by MATB CLK MDR 0 L or MATB CLK MDR 1 L or during a DATI or DATIP operation by MATC 325 NS DLY H which occurs about 25 ns after MATC OUTPUT ENABLE H. When OUTPUT ENABLE H goes unasserted, BUS SSYN L and the data are removed from the bus.

2.5.14 MATC 300 NS DLY H Signal

MATC 300 NS DLY H is an input to the write timing control which starts the write sequence (sheet MATD) unless a DATIP MODE is selected. MATC 300 NS DLY H is generated by the tap on pin 4 of delay line DL1.

2.5.15 MATD WRITE EARLY L Signal

MATD WRITE EARLY L is asserted by E10 (pin 8) at the beginning of the WRITE sequence and is unasserted by a timing signal on pin 8 of DL3 (approximately 350 ns later). MATD WRITE EARLY L turns on the X and Y write current generators and X and Y switches on the G235 module. It also turns off the same current generators and switches when it becomes unasserted.

2.5.16 MATD STACK CHG H Signal

MATD STACK CHG H is the complement of MATD WRITE EARLY L and is used as the input to the H217 stack charge circuit to reverse bias the unselected drive matrix diodes.

2.5.17 MATD WRITE LATE L Signal

MATD WRITE LATE L is the same as the MATD WRITE EARLY L signal but is delayed by 25 ns. It controls the turning on and off of the X and Y write drivers.

2.5.18 MATD INH TIME H Signal

MATD INH TIME H is generated during the write timing sequence. Its function is to provide timing for turning on the INHIBIT drivers.

2.5.19 WRITE LOCKOUT H Signal

The WRITE lockout flip-flop (sheet MATD) primarily determines the width of the pulse traveling down the delay lines DL3 and DL4. It is set by the 125 ns tap of DL4 and reset by MATD END OF WRITE L.

2.5.20 MATD END OF WRITE L Signal

The END WRITE flip-flop is set at the end of a write sequence. The output of the END WRITE flip-flop is combined with MATC SSYN L. As soon as SSYN becomes unasserted, which means that MSYN and SSYN have gone away, END OF WRITE L is asserted which indicates completion of the memory cycle. The END OF WRITE L signal resets the read and write lockout flip-flops at the end of a write sequence.

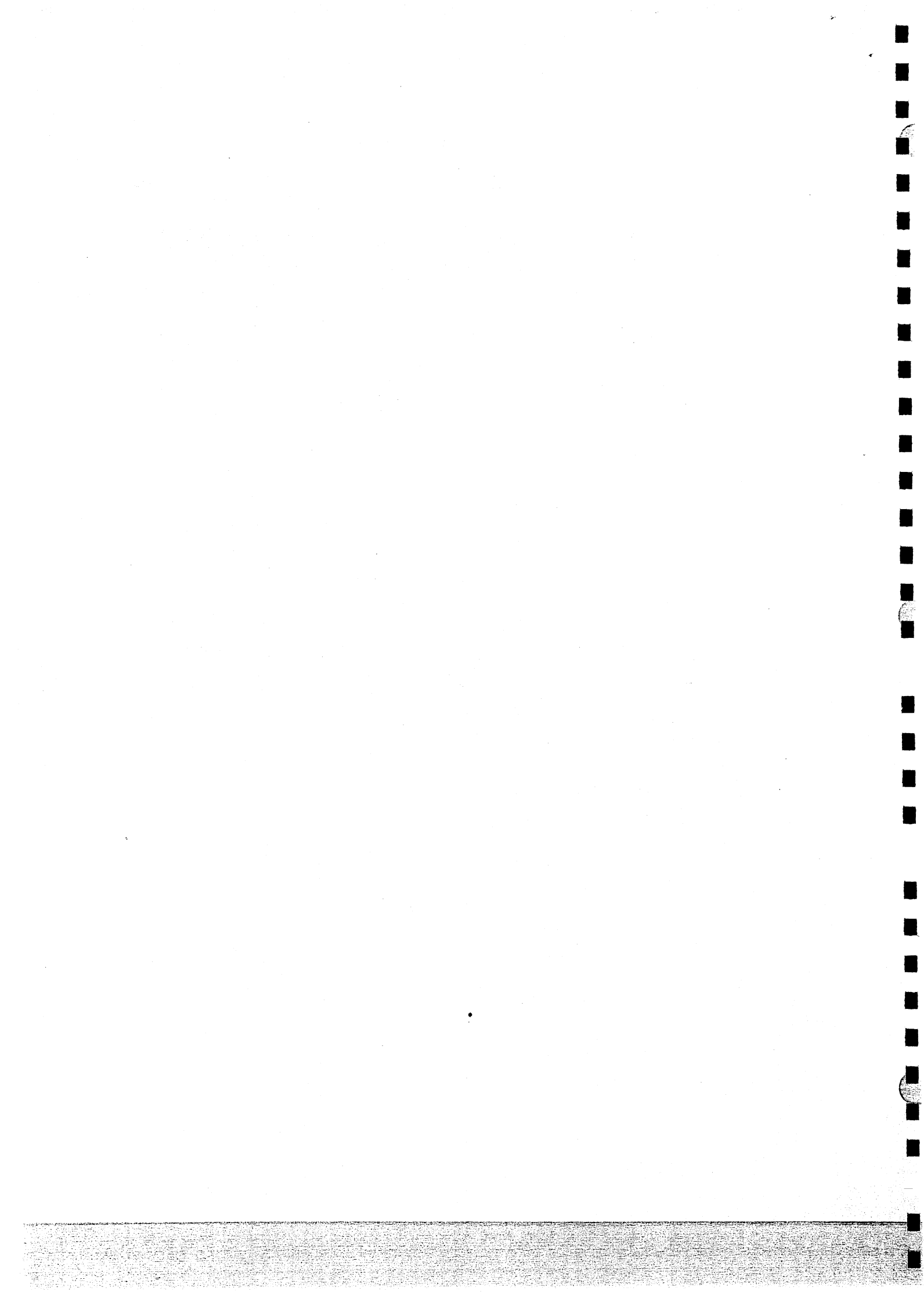

CHAPTER 3

DRIVER, SENSE AND STACK MODULES

3.1 INTRODUCTION

This chapter provides a detailed description of the MM11-U Memory. The detailed description covers the core array, switches and drivers, current generation, stack discharge circuitry, and sense/inhibit circuitry.

3.2 CORE ARRAY

The ferrite core memory consists of 16 memory mats (18 for MF11-UP) arranged in a planar configuration. Each mat contains 16,384 ferrite cores arranged in a 128 X 128 array. Each mat represents a single bit position of a word. This planar configuration provides a total 16,384 16-bit word locations (18 for MF11-UP). Each ferrite core can assume a stable magnetic state corresponding to either a binary 1 or a binary 0. Even if power is removed from the core, the core retains its state until changed by appropriate control signals. The outside diameter of each core is 18 mil; the inside diameter is approximately 11 mil. Each core is 4.5 mil thick.

Each core is threaded by three wires, providing means for selection and core switching. X axis read/write windings pass through all cores in each horizontal row for all 16 or 18 mats. Y axis read/write windings pass through all cores in each vertical row for all 16 or 18 mats. Through the use of selection circuits which control the current applied to specific X-Y windings, any one of the 16,384 word locations can be addressed for writing data into memory or reading data out of memory. A third line passes through each core on a mat to provide the sense/inhibit functions. There is one sense/inhibit line per mat. This single sense/inhibit line, as well as the selection circuits, are discussed in subsequent paragraphs.

3.3 MEMORY OPERATION

Figure 3-1 illustrates a typical portion of the core memory. X and Y wires pass through each core in the mat. The current passing through any one winding is such that no single winding produces a magnetic field strong enough to cause a core to change its magnetic state. Only the reinforcing magnetic field caused by the coincident current of both an X and a Y winding can cause the core located at the point of intersection to change states. It is this principle that allows the relatively simple wiring arrangement to select one and only one memory core out of the possible 16,384 contained on each mat. The current passing through either an X or Y winding is referred to as a half-select current.

A half-select current passing through the X3 winding (Figure 3-1) from left to right produces a magnetic field that tends to change all cores in that horizontal row from the 0 to 1 state. The flux produced by the current is, however, insufficient to complete the state transition in any core. Simultaneously passing a half-select current through the Y2 winding from top to bottom produces the same effect on all cores in that particular vertical row.

Note, however, that both currents pass through only one core which is located at the intersection of the X3 and Y2 windings. This is the selected core and the combined current values are sufficient to change the state of the core. The arrows in Figure 3-1 show current direction for the read cycle.

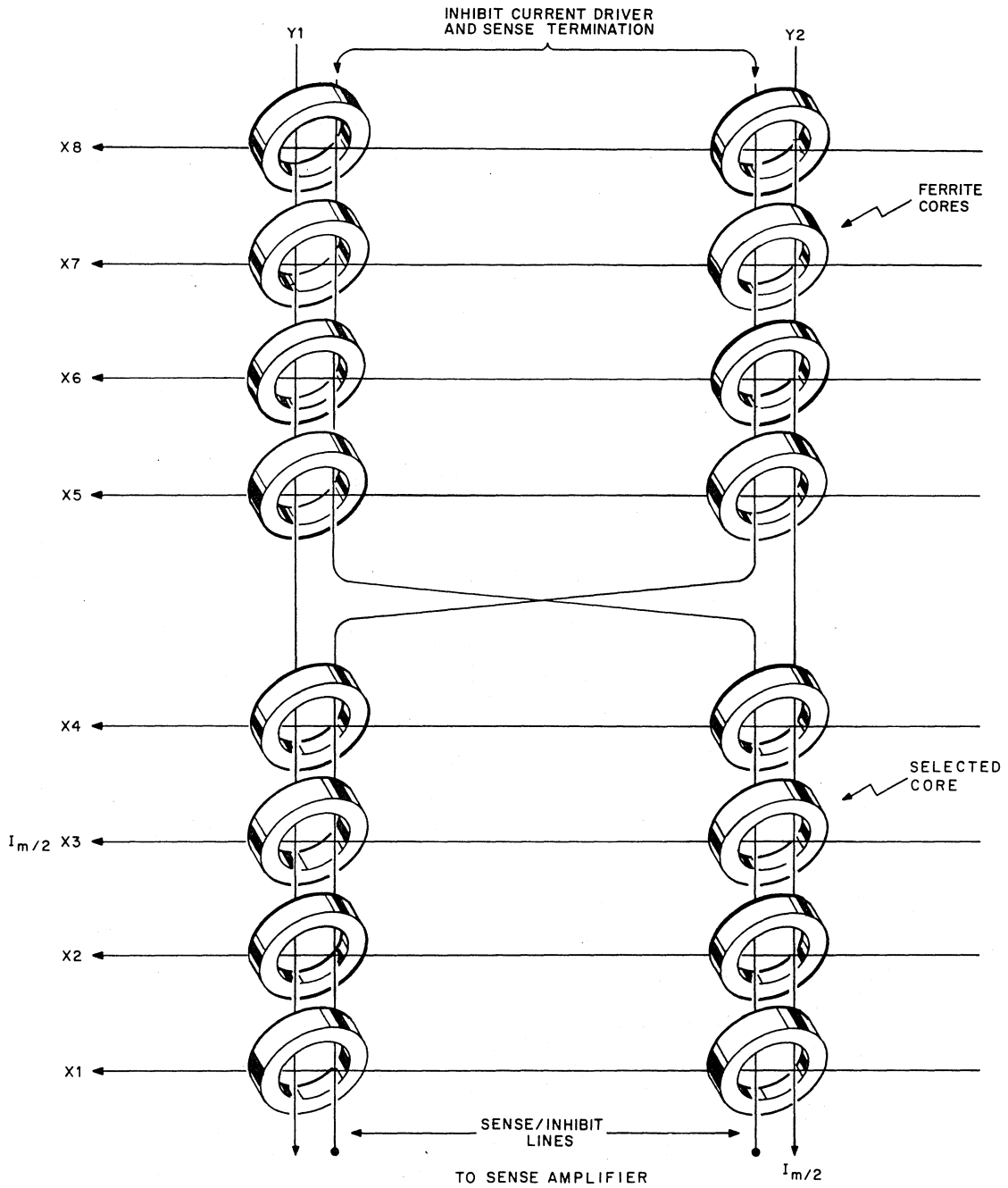

11-1790

Figure 3-1 Three-Wire Memory Configuration

All X and Y windings are arranged in such a manner that whenever a half-select current is passed through each, the resultant magnetic fields combine in the core at the point of intersection. This combined, full-select current ensures that the selected core is left in the binary 1 state. The currents used to select the core are referred to as read or write currents. A typical hysteresis loop for a core is shown in Figure 3-2. The loop is always traversed in the direction of the arrows.

HYSTERESIS LOOP FOR CORE

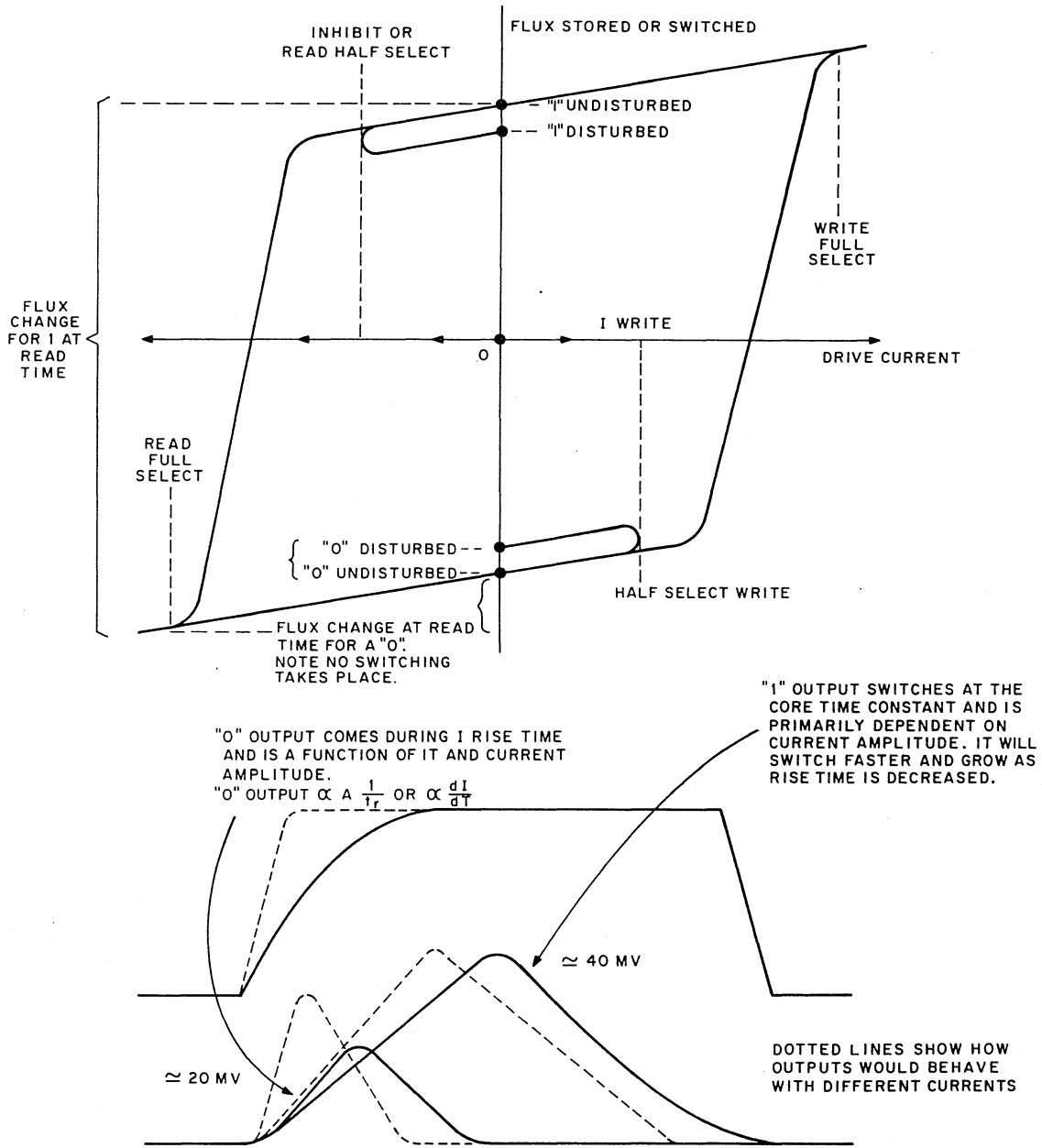

11-0088B

Figure 3-2 Hysteresis Loop for Core

In the MF11-U/UP Core Memory, the X3 windings in all 16 or 18 mats are connected in series, as are the Y2 windings. Therefore, whenever a full-select current flows through a selected core on one mat, it also flows through an identical core on the other 15 mats. The X3-Y2 cores on all mats switch to a binary 1, causing each of the 16 cores to become one bit of a 16-bit storage cell.

Because of the serial nature of the X-Y windings, a method must be employed to set certain cores to the 0 state; otherwise, every 16-bit word selected would be all 1s. The method used in the MF11-U/UP Core Memory is to first clear all cores to the 0 state by reading. During the write operation, cores on particular mats are inhibited by an inhibit winding. The inhibited cores remain 0s even when identical cores on other mats are set to 1s.

The half-select current for the inhibit lines is applied from an inhibit current driver, which is a switch and a current source between the inhibit line and +20 V. The current in the inhibit line flows in the opposite direction from the write current in all Y lines and cancels out the write current in any Y line. There is a separate inhibit driver for each memory mat, and each mat represents one bit position of a word; thus, selected bits can be inhibited to produce any combination of binary 1s and 0s desired in the 16-bit word. Remember that the inhibit function is active only during write time.

The sense/inhibit lines are also used to read out information in a selected 16-bit memory cell. The specific core is selected at read time in the same manner as during the write cycle, with one notable exception: the X and Y currents are in the opposite direction than they are for the write operation. These opposite half-select currents cause all cores previously set to 1 to change to 0; cores previously set to 0 are not affected. Whenever the core changes from 1 to 0, the flux change induces a voltage in the sense winding of that mat. This voltage is detected and amplified by a sense amplifier. The amplifier output is strobed into the data register for eventual transfer to the Unibus.

Figure 3-3 shows a 16-word by 4-bit planar memory. The MF11-U/UP Core Memory functions in the same manner except that it has 128 X lines, 128 Y lines, and 16 core mats. The core stringing is identical, and the sense windings are strung through all 16,384 cores with the interchange between X63 and X64, instead of between X1 and X2.

3.4 X AND Y DECODING

The basic decoding units are type 7442 and 74154 4-line to 10-line, and 4-line to 16-line decoders. The inputs are D0, D1, D2, and D3; they are weighted 1, 2, 4, and 8, with D0 being the least significant bit. An output is selected according to the sum of the weighted inputs. The selected output is low and all others are high. See Appendix A for truth tables of 7442 and 74154 decoders. Each 7442 controls eight read/write driver pairs and each 74154 controls sixteen read/write switch pairs. This switch matrix is combined with the stack X-Y diode matrix to allow selection of any location out of the total 16,384 locations (see stack drawing D-CS-H217-0-1 for interconnections).

The X and Y line switches are first differentiated as switches and drivers. The drivers are those switches that are connected to the diode end of the stack. Drivers and switches are further differentiated by function: either read or write. Another differentiation is made by polarity: negative or positive, depending on the physical connection. Read switches and write drivers are connected to the current generator outputs and are considered positive; write switches and read drivers are connected to ground and are considered negative.

3.5 DRIVERS AND SWITCHES

Drivers and switches direct the current through the X and Y lines in the proper direction as selected by the read and write operations. Each switch or driver is addressed by one decoder output. A low decoder output selects the associated read and write switch or driver. The 74154 decoders are connected to switches, and the 7442 decoders are connected to drivers.

In the MF11-U/UP Memory, 16 pairs of read/write switches and 8 pairs of read/write drivers are provided in the X axis; 16 pairs of read/write switches and 8 pairs of read/write drivers are provided in the Y axis. In conjunction with the stack diode matrix (drawing H217-0-1), this allows selection of 128 lines in the X axis and 128 lines in the Y axis. This provides a 128 X 128 matrix that selects any location out of 16,384 locations.

Figure 3-4 illustrates a portion of a Y selection matrix and shows the interconnection of the diodes and the lines from the switches and drivers. It shows how 4 pairs of switches and drivers are connected to select one of 16 lines. Refer to drawing H217-0-1, for an extension of this method which uses 16 pairs of switches and 8 pairs of drivers to select one of 128 lines.

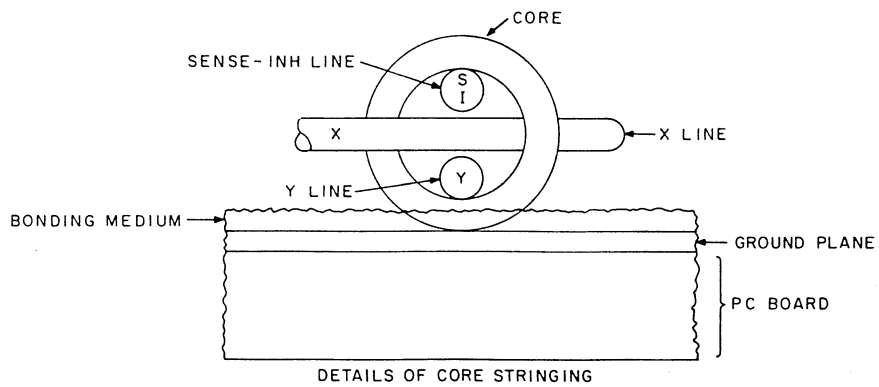
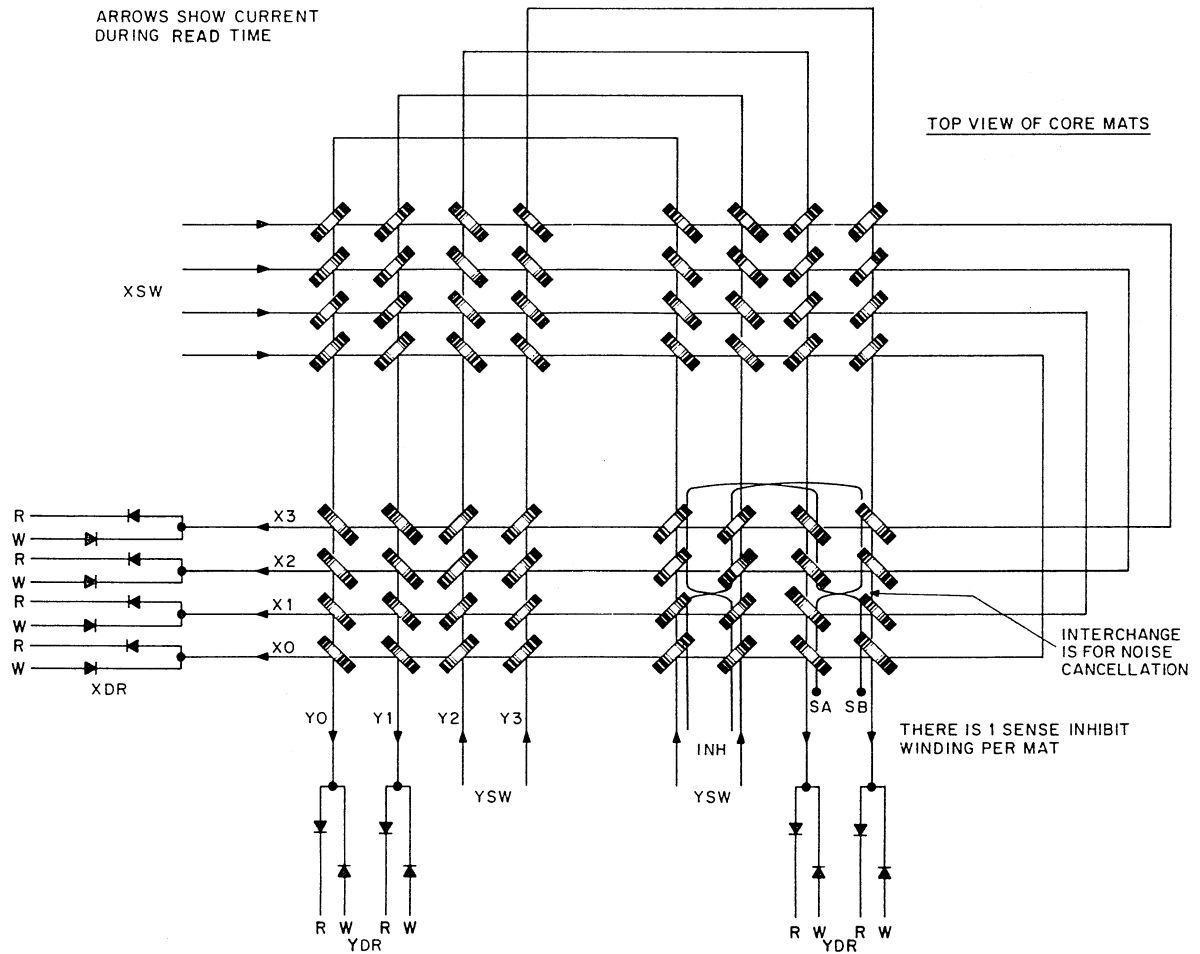

11-1791

Four mats shown for a 16-Word by 4-Bit Memory

Figure 3-3 Three-Wire 3D Memory

NOTE :

A matrix this size would be used in a system having 16 Y drive lines. The MF11-U/UP contains 128 Y drive lines on an 8 x 16 matrix.

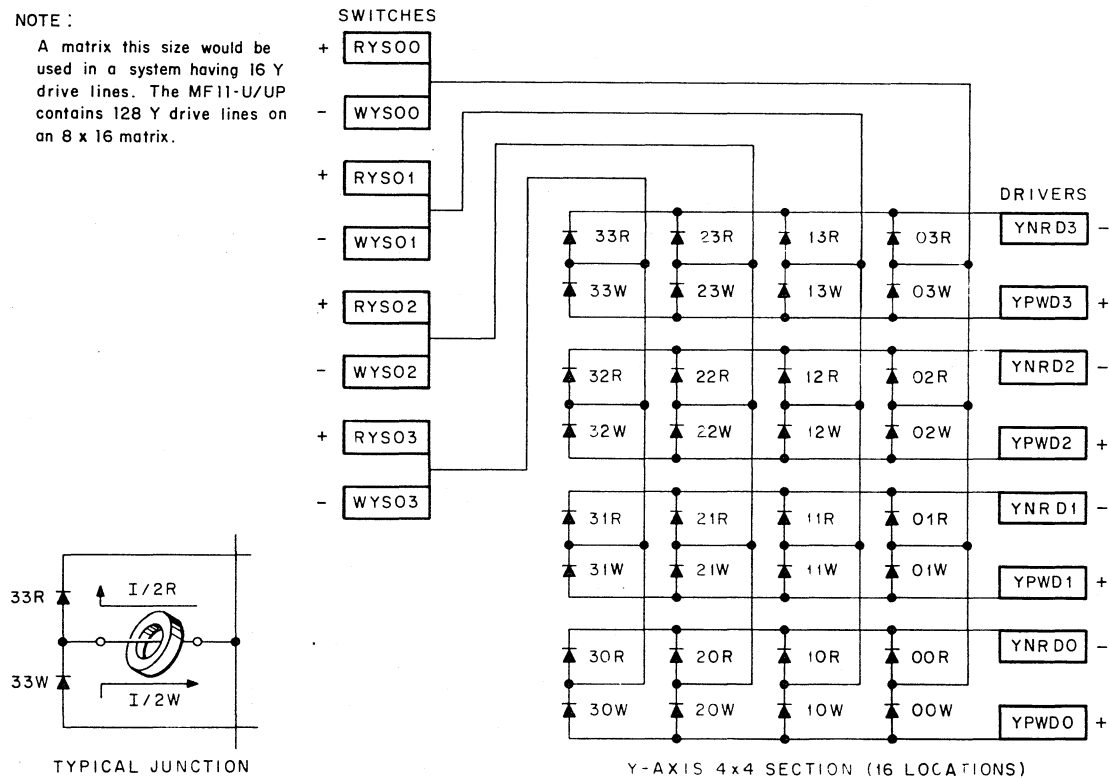

Figure 3-4 Simplified Y Line Selection Stack Diode Matrix

To illustrate the operation of the actual X matrix or Y matrix, a smaller, but analogous, Y matrix is shown in Figure 3-4. This matrix shows four pairs of drivers and four pairs of switches for a Y axis (16 Y drive lines).

Polarities are shown for convenience. The diodes are identified to assist in associating them with the drivers and switches. Each line from a twin diode interconnection to a read/write switch pair passes through 128 cores and represents one line on each bit mat. Assume that a read operation is to be performed and the word address decoders have selected read switch RYS00 and read driver YNRD1. The Y current generator sends current through read switch RYS00 (conventional flow) which puts a positive voltage on the anodes of diodes 03R, 02R, 01R, and 00R. The non-selected read drivers (YNRD3, YNRD2, and YNRD0) provide a positive voltage on the cathodes of their associated diodes (03R, 02R, and 00R, respectively) which reverse biases them and prevents conduction. Read driver YNRD1, which has been selected, turns on and makes the cathode of diode 01R negative with respect to the anode which forward biases it. The diode conducts and allows current to flow to write driver YNRD1. A half-select current now flows through this line that links 128 cores per bit mat (2048 total for 16 mats).

Figure 3-5 is a simplified schematic of two pairs of switches and drivers in the MF11-U/UP interconnected with the core stack and current generator. Read/write switches YS07 and read/write drivers YD7 are used as examples. These switches and drivers are chosen for convenience. For a read or write operation, there are 128 switch/driver combinations on the Y axis and 128 on the X axis. For a write operation, decoder E19 selects positive write driver E25 and decoder E28 selects negative write switch E14. Both E25 and E14 are turned on when they are selected and write timing occurs. E25 conducts, which allows current from the Y write current generator to flow through nH25, the associated matrix diode, and the cores on the selected line. After passing through the cores, the current flows

3-7

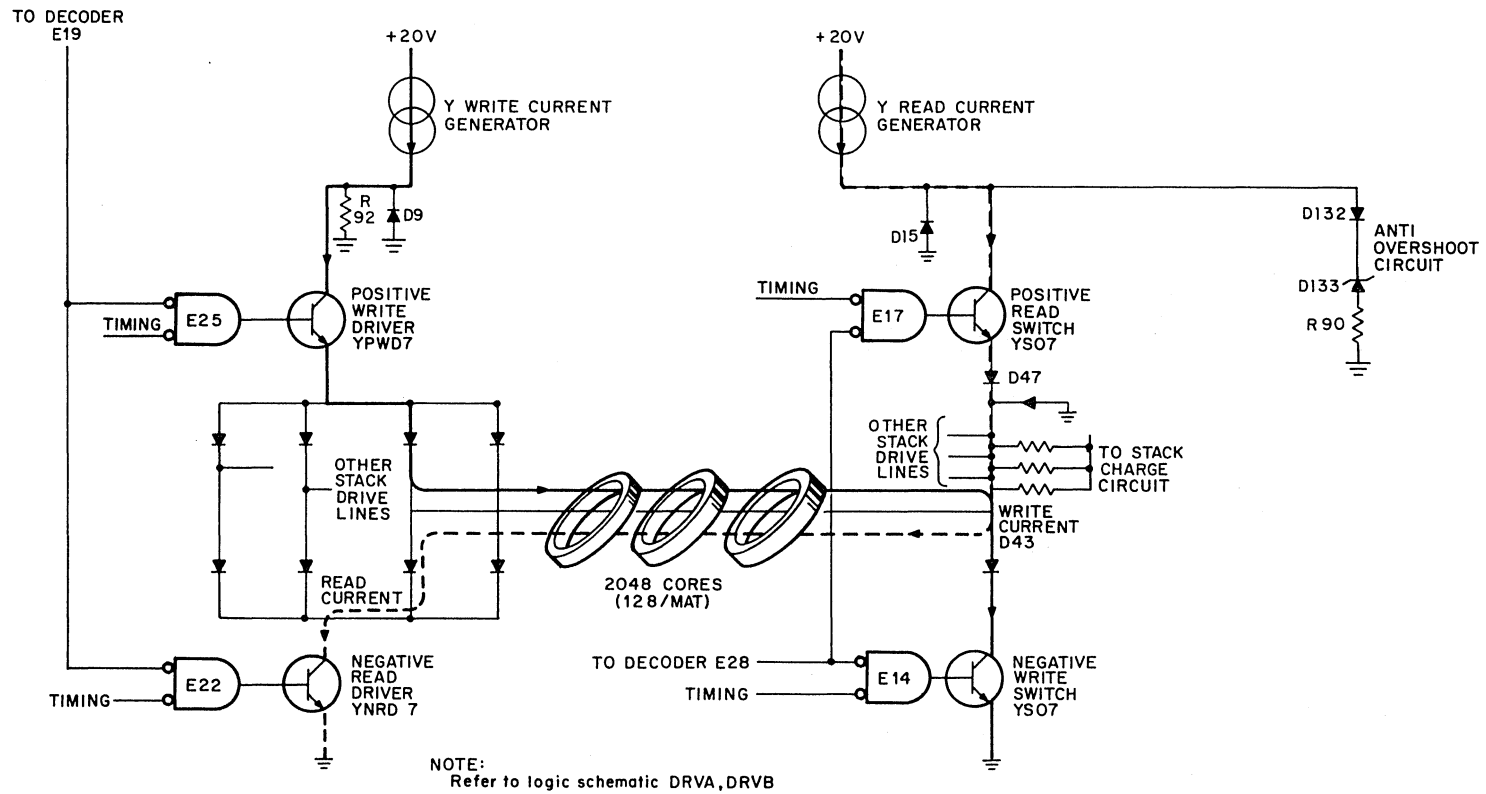

11-1784

Figure 3-5 Typical Y Line Read/Write Switches and Drivers

through D43 and E14 to ground. For a read operation, decoder E28 selects positive read switch E17 and decoder E19 selects negative write driver E22. Both E17 and E22 are turned on by read timing. E17 conducts, which allows current from the Y read current generator to flow through E17, D47, and the cores in the opposite direction. After passing through the cores, the current flows through the associated matrix diode E22 to ground. Read current flow is shown as a broken line; a solid line shows write current flow.

3.5.1 Word Address Decoding and Selection Sequence

This paragraph takes a specific word address through the decoding and X and Y line selection sequence. The word address is 017772 and it is assumed that a specific memory bank has been selected. The binary equivalent of the address is shown below. A read operation is to be performed.

ADDRESS BITS A<17:00>																	BIT POSITION	
17	16	15	14	13	12	11	10	09	08	07	06	05	04	03	02	01	00	BINARY
0	0	0	0	0	1	1	1	1	1	1	1	1	1	1	0	1	0	
0			1			7			7			7			2		OCTAL	

11-1173

Bits A(14:01) are used to decode the word address. Bits A(14:01) are sent from the Unibus receivers to inputs to the associated word latches. Table 3-1 shows the state of bits A(14:01) and the decoding signals generated by the word address latches.

Table 3-1
Example of Word Address Decoding Signals

Address Bit	Unibus Receiver Input	Receiver Output	Latch State	Latch Output Signals
A01	L	H	set	A01H=H
A02	H	L	reset	A02H=L
A03	L	H	set	A03H=H
A04	L	H	set	A04H=H
A05	L	H	set	A05H=H
A06	L	H	set	A06H=H
A07	L	H	set	A07H=H
A08	L	H	set	A08H=H
A09	L	H	set	A09H=H
A10	L	H	set	A10H=H
A11	L	H	set	A11H=H
A12	L	H	set	A12H=H
A13	H	L	reset	A13H=L
A14	H	L	reset	A14H=L

The decoders, switches, and drivers are shown in drawing G235-0-1, sheets 4 and 5. Using the decoding signals in Table 3-1 and the operating characteristics of the decoders, it is possible to determine which decoder outputs have been selected for word address 017772.

Decoder E19 – D2 is high, D1 is low, D0 is high; selects output 5 (pin 6) which is read driver YNRD5.

Decoder E28 – D3 is low, D2 is high, D1 is high, D0 is high; selects output 7 (pin 8) which is read switch YS07.

Decoder E32 – D2 is high, D1 is high, D0 is high; selects output 7 (pin 9) which is read driver XNRD07.

Decoder E27 – D3 is low, D2 is high, D1 is low, D0 is high; selects output 7 (pin 8) which is read switch XS07.

The last step is to follow the outputs of the drivers and switches to the stack diode matrix (drawing H217-0-1, sheet 2). For the X line, the circuit is from driver XNRD7 to diode junction E18-7, across termination 93 to switch XS07. For the Y line, the circuit is from driver YNRD5 to diode junction E7-7, across termination 79 to switch YS07. The terminations indicate the point on the stack printed circuit board where the X or Y line is soldered. Physically, the wire that is connected across the termination is strung through 128 cores per bit mat (total of 2048 cores in series for 16-bit memory).

3.6 READ/WRITE CURRENT GENERATION AND SENSING

3.6.1 Introduction

Aside from the addressing and control logic, four functional units are involved in generating current to switch the cores and detect their state. The X and Y line read and write current generators supply the drive current (via switches and drivers); the inhibit drivers allow 0s to be written during a write operation; the sense amplifiers detect 1s during a read operation; and the memory data register (MDR) temporarily stores data to be written or data that has been read from the memory. The following paragraphs discuss each functional unit and their interrelation.

3.6.2 Read/Write Operations

The discussion of the read/write operations shows the interrelation of the current generator, inhibit drivers, sense amplifiers, and memory data register. Details of the operation of each functional unit are discussed in subsequent paragraphs. Several control signals are mentioned; however, details of their generation and timing are described in Chapter 2.

For clarity, one data bit (D07) of the selected word is discussed and the text is referenced to Figure 3-6 which is a simplified block diagram. Detailed logic for the MDR, Unibus receivers and drivers, sense amplifiers, and inhibit drivers for all 16 data bits is shown in drawing G114-0-1.

During a read operation, half-select currents flow in the X and Y lines for the selected word in each bit mat. These currents flow opposite to the write currents; therefore, cores in the 1 state are switched to the 0 state and cores in the 0 state are unchanged. Switching the core from the 1 state to the 0 state induces a voltage pulse in the sense winding. This pulse is detected by sense amplifier E401 as a differential voltage on input pins 6 and 7 if it exceeds the threshold reference voltage. This pulse is amplified and when SINA SENSE STROBE 0 H is generated at pin 11, the output of sense amplifier E401 goes high. Just prior to the strobe signal, the control logic generates SINA CLEAR MDR 0 L which clears (resets) flip-flop E404. The sense amplifier output is inverted by E403 and sent to the preset input (pin 10) of MDR flip-flop E404. A low on the preset input sets the flip-flop; its 1 output (pin 9) is a high and its 0 output (pin 8) is a low. The high from pin 9 of the flip-flop is sent to input pin 12 of Unibus driver E407. The other input to E407 is the buffered OUTPUT ENABLE signal. When the control logic generates SINA OUTPUT ENABLE H, the output of E407 is low (logical 1 for Unibus logic). This is the readout of bit D07 and is sent to the requesting device via the Unibus. Timing diagrams for the sense operation are shown in Figure 3-7.

3-10

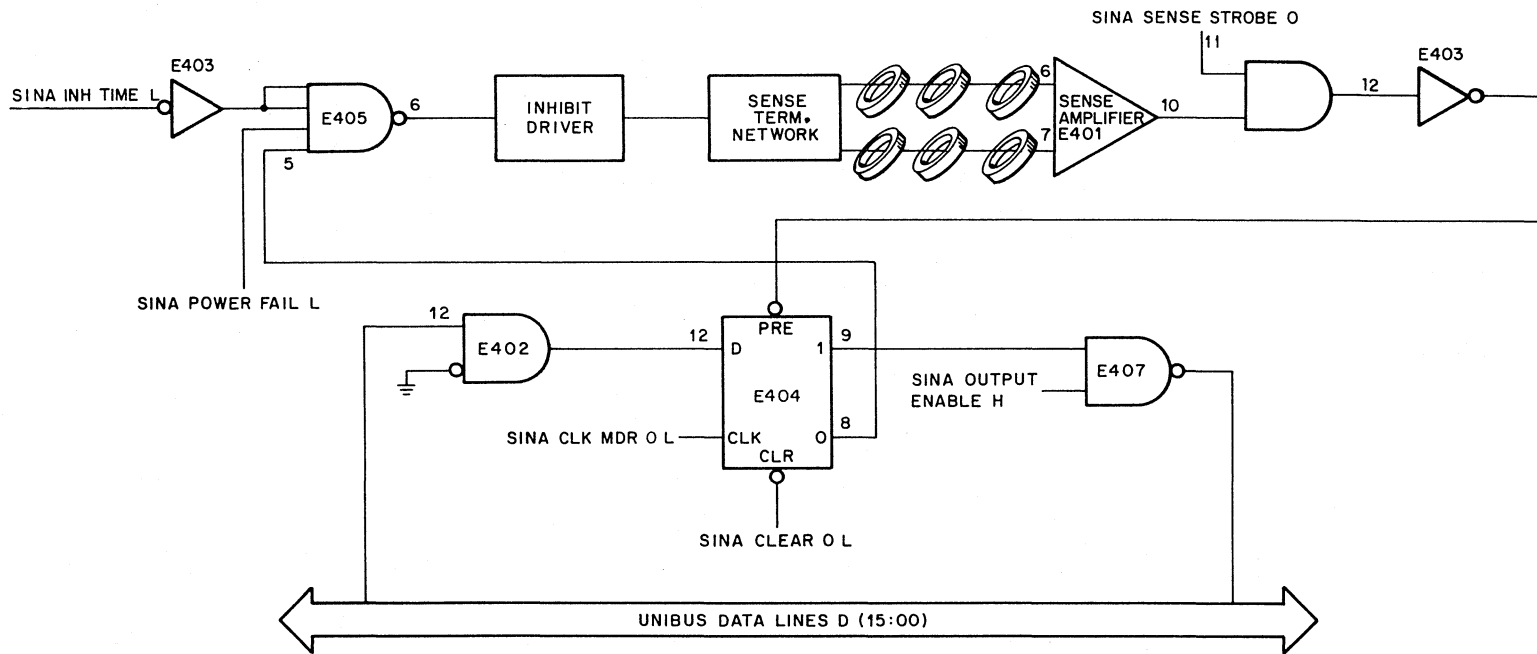

11-1782

Figure 3-6 Interconnection of Unibus, Data Register, Sense Amplifier and Inhibit Driver

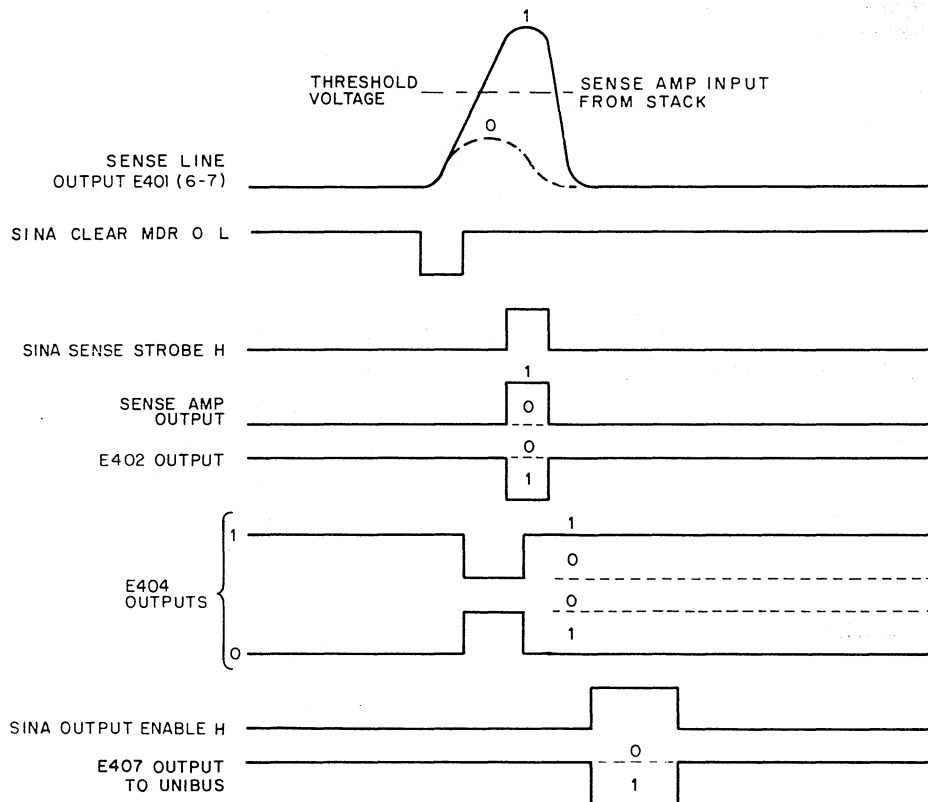

NOTE :
 Refer to figure 5-3 for
 typical circuit schematic
 and refer to figure 5-4
 for waveforms.

11-1192

Figure 3-7 Sense Operation Timing Diagram

The read operation is destructive: all cores at the specified location are now 0. The data that was read must be restored by a write operation which immediately follows the read operation. Flip-flop E404 is still in the set state; therefore, its 0 output (pin 8), which is low, is sent to input pin 5 of NAND gate E405. The control logic generates the inhibit driver control signal SINA INH TIME L which is buffered by E403 and sent to another input of gate E405. The gate is not turned on (pin 5 is low) and the inhibit driver is not turned on. With no inhibit current in the inhibit line to oppose the half-select Y line current, a 1 is written back into the appropriate cores.

In this example, if bit D07 is a 0 in core, it does not switch during the read operation and the output of sense amplifier E401 does not go high. Flip-flop E404 remains cleared (reset): its 1 output (pin 9) is low and its 0 output (pin 8) is high. When the control logic generates SINA OUTPUT ENABLE L, the output of Unibus driver E407 is high (logical 0 for Unibus logic). The 0 output of flip-flop E404, which is high, is sent to NAND gate E405. During the subsequent write operation, SINA INH TIME L is generated which produces a low output signal at E405 pin 6. This activates the inhibit driver which produces a current that opposes the Y line current and prevents a 1 from being written into this bit of the selected word.

The read/write operation which has been discussed is a read/restore operation (DATI). The requesting device wants to read a word from memory and, as an internal requirement, the memory must restore the word by writing it back in core. In this case, the MDR flip-flops are preset by the sense amplifier outputs when 1s are read from the core. The flip-flop outputs are used in the subsequent write (restore) operation to control the inhibit drivers. If the requesting device wants to write a word into memory (DATO), it must load the data into the MDR flip-flops. The

device asserts the data on the Unibus from which it is picked off via Unibus receivers. In this example, bit D07 is sent to pin 9 of Unibus receiver E402. The bit is inverted by the receiver and sent to the D input (pin 12) of flip-flop E404. At the start of the DATO cycle, the control logic generates SINA CLK MDR 0 H which clocks the flip-flop. If the D input is high, E404 is set and its 0 output is low. Control gate E405 is not asserted by SINA INH TIME L and the inhibit driver is not turned on. A 1 is written into the selected core. If the D input is low, E404 is reset and its 0 output is high. Control gate E405 is asserted by SINA INH TIME L and the inhibit driver is turned on. A 0 is written into the selected core. Because SINA CLEAR 0 L and SINA SENSE STROBE 0 H are disabled in this mode, the read operation is used only to magnetically clear the cores.

3.6.3 X and Y Current Generators

A read and write current generator is provided for both the X and Y drive lines. The current generators and associated bias current supply are shown in drawing G235-0-1, sheet 6.

Optimum core switching requires current pulses of precise amplitude, duration, and shape. The current amplitude is controlled by the dc bias current supply (which is temperature compensated). Pulse shaping is achieved by resistor, diode, zener diode, anti-overshoot circuits; duration is controlled by the timing pulses from delay lines.

Figure 3-8 shows the bias current supply and read X current generator. The heart of the current generators on both the G235 (X-Y current generators) and the G114 (inhibit current generators) modules are special saturating transformers. T2 is the saturating transformer for the read X current generator. T2 is normally saturated very hard by bias current in the winding designated with pins 3 and 12. In order for the magnetic core of T2 to start to switch its magnetic flux in the opposite direction, the ampere turns applied by the bias current needs to be exceeded by an equal but opposite current in another winding. As long as T2 remains saturated it is a low impedance to changes in current in any of its windings; however, once T2 starts to switch magnetic flux, large voltages may be induced across its windings in response to any additional changes in net current. That is, T2 acts like an ideal current source – low impedance with less than a specified current in winding 2-13 and a high impedance to additional current changes once the specified current amplitude is reached. This specified current is primarily determined by the bias current amplitude and the turns ratio of T2. The third winding of T2 (1-14) conducts current only after the drive current pulse has ended, and restores some current to the +20 V supply during that period. Although some losses occur in T2, most of the energy absorbed by T2 during the current pulse is restored to the power supply at the end of the pulse.

The bias current supply provides the dc bias current required for all the saturating transformers on the G235 and G114 modules (in series). LRC filter networks are provided at intervals to ensure that the bias current does not acquire ac components and to ensure that large voltages do not build up along the series path. (L1, C43, and R17 comprise such a filter network protecting Q12 and Q13 from transients.) The resistor network, consisting of the stack thermistor, R10, R9, R11, R12, R8, R7, R13, R14, R15, and Zener diode D1, provides a temperature compensated reference voltage to pin 3 of E1. R2 feeds back the emitter voltage of Q12 to pin 2 of E1. The 741 operational amplifier uses its gain to adjust its output (pin 6) so that the voltage on pin 2 is made very nearly equal to the voltage on pin 3. In this way the amplifier circuit causes a current to flow through R4 and R5 controlled precisely by the reference voltage on pin 3 of E1. By measuring the voltage on AK2 with respect to +5 V, a very accurate measure of the bias current can be made, since most of the current through R4 and R5 finds its way through the collectors of Q12 and Q13 (Q13 base current is small) and becomes the bias current.

NOTE

The memory protection circuits and the circuitry to detect loss of bias current are described in Chapter 2.

Module pins AN2 and AU1 provide a means of changing the amplitude of the bias current. Grounding AU1 through a 470 K Ω resistor will cause the bias current to be reduced, and grounding AN2 through a 470 K Ω resistor will increase the bias current. This capability becomes important for margining the memory.

CAUTION

Jumpers W5, W6, W7 are factory cut to adjust the bias current to its optimum value and they should not be changed.

In Figure 3-8 the operation of the read X current generator is as follows. The output of E7 (pin 8) will go low when the current generator turns on. Current is coupled through T1 to saturate transistor Q1. At this point, current may flow through T2 windings (pins 13 and 2 and 14 and 1), through Q1, and to the read X switches. Diodes D17 and D16 limit the voltage applied to the read X switches and thus make the read X current rise time less dependent on the accuracy of the 20 V power supply. This is the only current generator in the memory with such a control. It is needed here because the core output signal is more dependent on the read X current rise time than any other. (Read Y current flows before the read X, hence the read X current does the actual core switching.)

D130, D131, and R89 form an anti-overshoot circuit which conducts current only during the rise time of the current. Its function is to "steal" some of the read current during the rise time so that when the current overshoot occurs, the overshoot only serves to bring the current quickly up to its proper value (and not beyond it).

R61 and C47 primarily serve as a dc current limit and as a rise time aid, respectively.

When Q1 is turned off by E7 (coupling through T1) current will flow through D30 until the core of T2 has been completely re-saturated by the bias current. This places energy back in the power supply.

3.6.4 Inhibit Driver

A detailed schematic of the inhibit driver for bit D07 is shown in Figure 3-9; it is typical of all 16 inhibit drivers (drawing G114-0-1).

When the inhibit driver is off, none of the pulsed currents shown in the schematic are flowing; transistor Q401 is off. The output of NAND gate E405 goes low (ground) when this inhibit driver is selected. Current i_1 flows into the output circuit of E405 from the +5 V supply via resistor R404 and the primary winding (terminals 9 and 10) of transformer T402. An equal current is induced in the base-emitter circuit of Q401 which is connected to the transformer secondary winding (terminals 8 and 7). This base current turns on Q401. Current i_1 , and therefore induced current i_2 , is determined by resistor R404 and the reflected base-emitter voltage, V_{be} , of Q401. When Q401 is turned on, current flows from +20 V through the saturating transformer T403, transistor Q401, fuse F401, isolation diodes, and the sense/inhibit winding to the isolation diodes D403 and D404 to ground. The value for inhibit current is primarily determined by the bias current to T403 (winding 7-8).

Each leg of the sense/inhibit sees half the inhibit current; approximately 370 mA. Capacitor C407 and D405 help reduce the power dissipated in Q401 during turn-off.

The inhibit driver is turned off when the output (pin 6) of gate E405 goes from low to high. At turn-off time, the back emf caused by the stack inductive reactance tries to drive the emitter of Q401 highly negative; however, diode D407 and resistor R409 help to clamp this voltage to ground. When the output of E405 goes high (approximately +3.2 V), its output pull-up transistor (an integral part of the gate circuit) tries to drive the turn-off current i_4 in the opposite direction through the transformer primary winding. An equal current induced in the secondary winding removes the forward bias from the base of Q401 and turns it off. With Q401 off, all dynamic current flow ceases in the circuit.

Capacitor C410 allows the gate to pump reverse current i_4 into the transformer primary; it also helps to decrease the turn-on time of Q401. Diode D405 prevents reverse breakdown of the base-emitter junction of Q401.

3-15

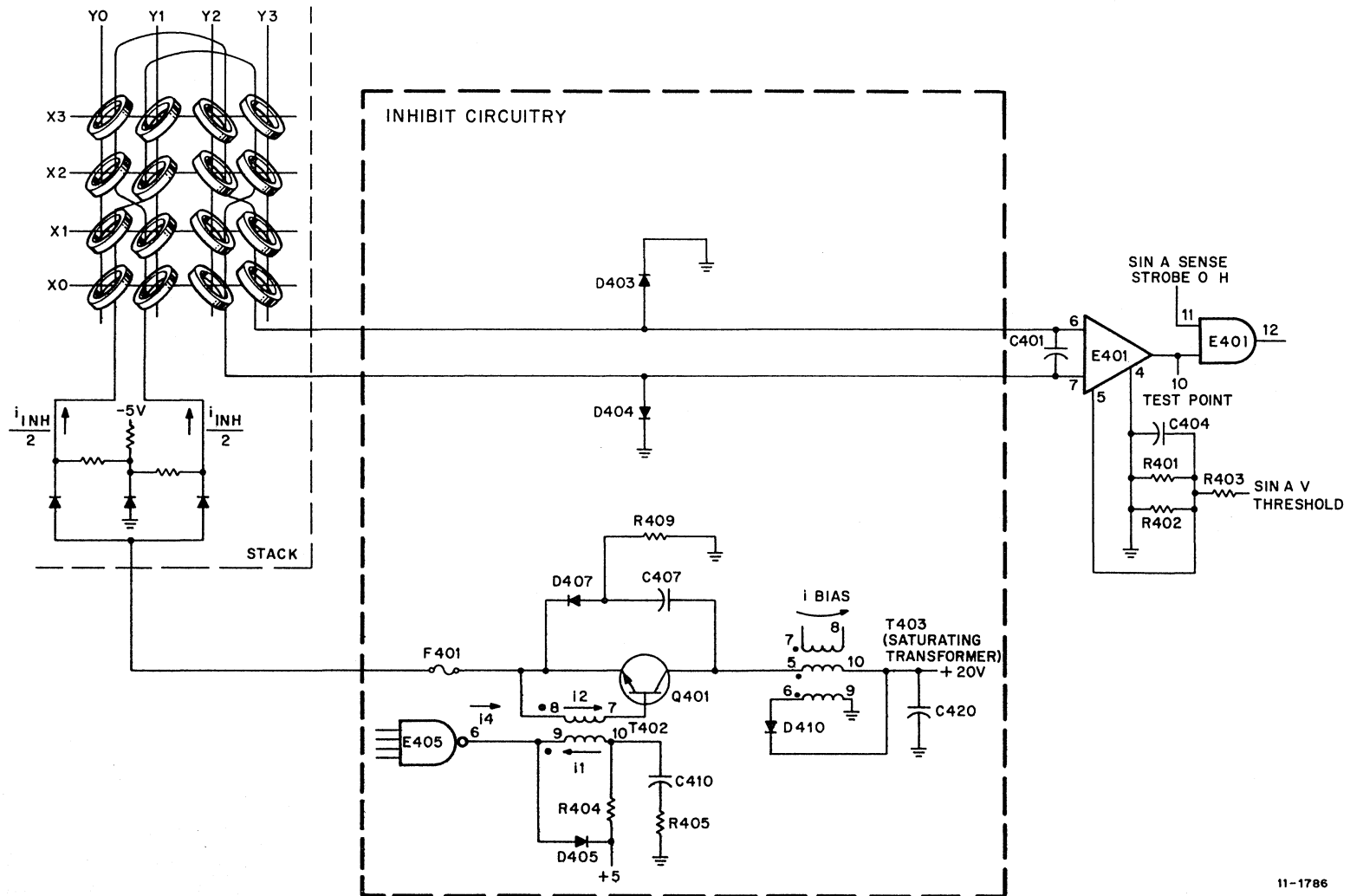

Figure 3-9 Sense Amplifier and Inhibit Driver

3.6.5 Sense Amplifier

A detailed schematic of the sense amplifier circuit for bit D07 is shown in Figure 3-9; it is typical of all 16 sense amplifier circuits (drawing G114-0-1). It consists of the sense amplifier, terminating capacitor for the sense/inhibit winding, and threshold voltage network.

The sense amplifier input (E401 pins 6 and 7) is across the sense/inhibit winding (STKA SA7 and STKA SB7). Practically speaking, during the sense operation, the inhibit driver connection is an open circuit through the driver transistor Q401. The effect of the inhibit driver circuit, and isolation diodes D403 and D404 can be ignored during the sense operation because the diodes are reverse biased.

Sense amplifier E401 is one-half of a dual IC package (type 7528). A simplified block diagram of the package is shown in Figure 3-10. The two identical circuits are marked 1 and 2. Each consists of a preamplifier and sense amplifier. The output of the preamplifier is available as a test point to observe the amplified core signal and to facilitate accurate strobe timing. Both circuits share a reference voltage (or threshold voltage) amplifier (pins 4 and 5). In this application, pin 4 is grounded and a positive threshold voltage of approximately 17 mV is supplied to pin 5. This voltage is obtained from the +5 V supply through resistor voltage dividers. Operation of the sense amplifier is discussed in Paragraph 3.6.2.

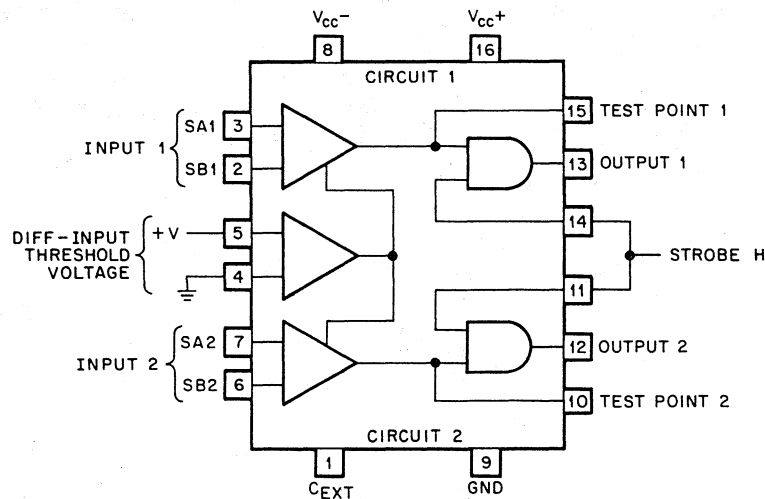

11-1103

Figure 3-10 Type 7528 Dual Sense Amplifiers with Preamplifier Test Points

3.6.6 Memory Data Register

The memory data register (MDR) is a 16-bit flip-flop register that is used to store a word after it is read out of the memory, or to store a word from the Unibus prior to its being written into the memory. It is composed of eight 74H74 dual high-speed D-type flip-flops. At the start of a memory read operation, the MDR is cleared directly via the CLEAR input (pin 1 or pin 13) of each flip-flop; the clear signal is SINA CLEAR 0 L for bits D00–D07 and SINA CLEAR 1 L for bits D08–D15. The operation of the MDR during a read/restore operation (DATI) and a write operation (DATO) is discussed in Paragraph 3.6.2.

3.7 STACK CHARGE CIRCUIT

The stack charge circuit assists the stack capacitance in recovering and shortens the rise time of the stack current. It also reduces unwanted currents in the seven unselected lines associated with the selected driver. It is located on the H217 module.

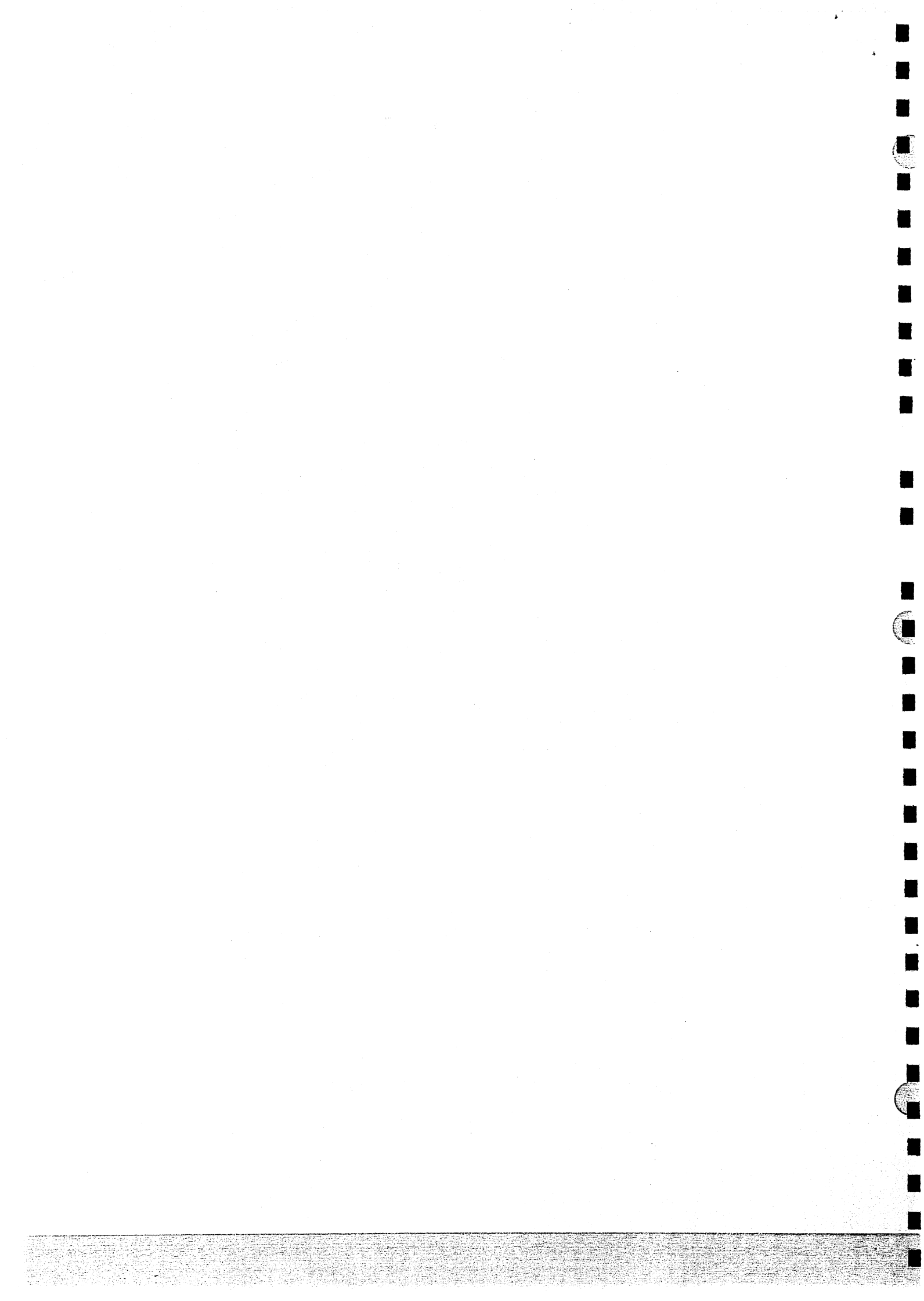

CHAPTER 4

MF11-UP CORE MEMORY WITH PARITY

4.1 INTRODUCTION

This chapter contains a description of the theory and operation of the MF11-UP parity memory and the M7259 Parity Controller. Inasmuch as the MF11-UP is similar in operation to the MF11-U Memory, which is described in the main body of this manual, only those areas of operation which are unique to the MF11-UP are covered in this chapter.

NOTE

An M7259 Parity Controller Module must be Etch Rev D and CS Rev E or higher to be useable in the MF11-UP.

4.2 DESCRIPTION

The parity memory consists of an M8293 16K Unibus Timing Module, a G235 Driver Module, a G114 Sense Inhibit Module, and an 18-bit H217-C Stack Module. In addition, an M7259 Parity Controller Module is required. The M7259 Parity Controller performs all parity generating and checking functions and communicates with memory via an internal bus shown in Figure 4-1. The signals on the internal bus are shown in Figure 4-2 and are described in Paragraph 4.6.2. The parity controller processes 16K or 32K of memory (two MF11-UPs). Bits 16 and 19 are the parity bits for the low byte and high byte, respectively. These bits are the property of the parity controller and are not accessible to the PA and PB lines on the Unibus. Bits 17 and 18 are not used in the MF11-U or the MF11-UP. The stack may or may not contain the cores and/or electronics for these bits even though they are shown on the circuit schematic.

In a DATO or DATOB bus cycle, both the low order and high order bytes are coded for odd parity; thus, for every byte containing an even number of 1s, a 1 is written into the corresponding parity bit location.

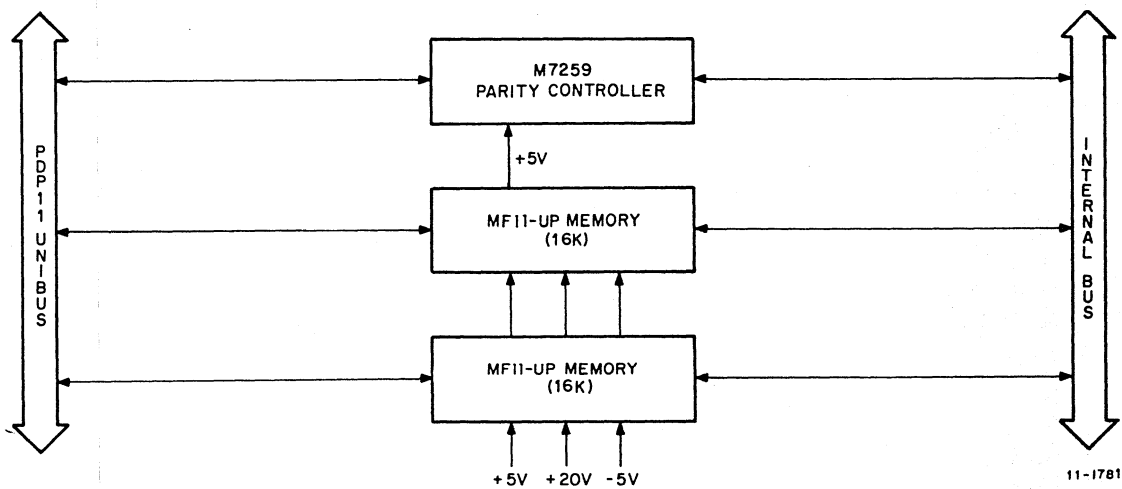

Figure 4-1 Parity Controller Internal Bus

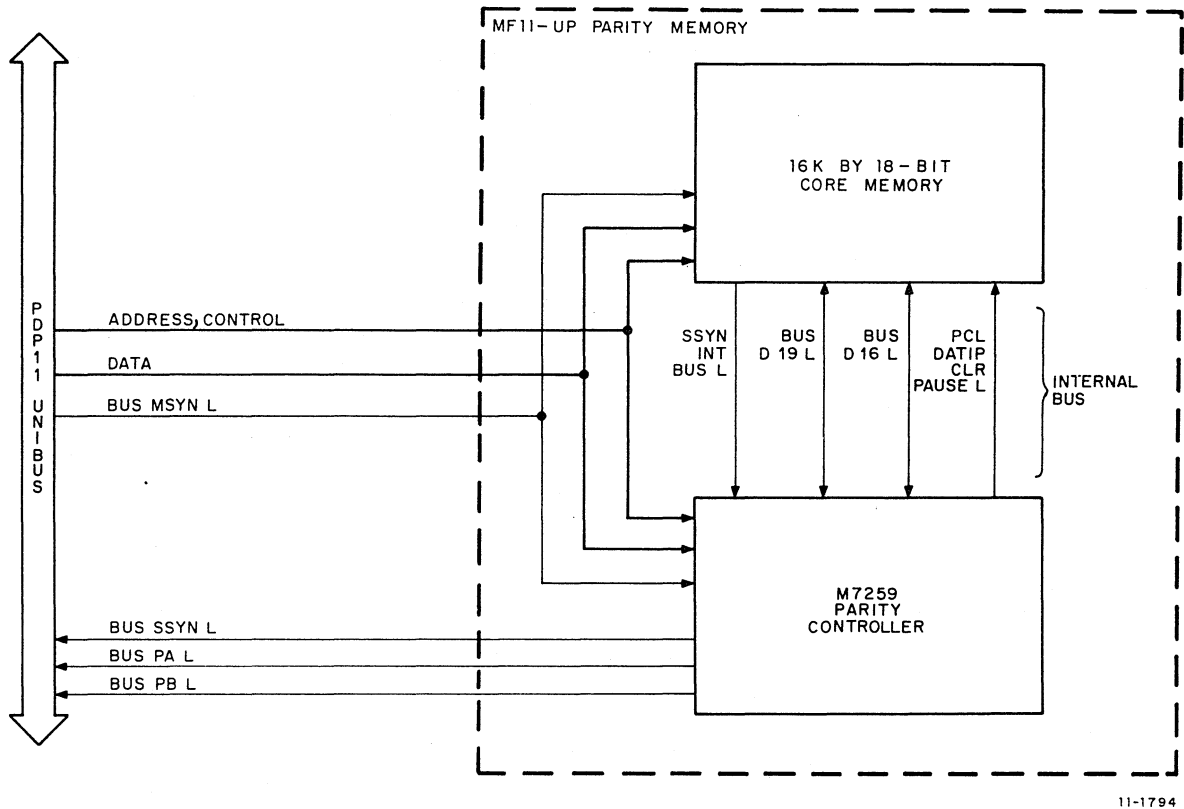

Figure 4-2 Parity Controller Block Diagram

In a DATI or DATIP bus cycle, each byte plus its associated parity bit is checked for an odd number of 1s. If the sum is even, an error condition exists. When a parity error is detected during a DATIP, the erroneous data causing the parity error is saved and written back into core.

4.3 SPECIFICATIONS

The specifications of the M7259 Parity Controller are given in Table 4-1. Table 4-2 shows the cycle and access times for the MF11-UP Memory option.

Table 4-1
M7259 Parity Controller Specifications

Voltage Requirements:	+5 V \pm 5% with less than 0.05 V p-p ripple
Current Requirements:	1.2 A Maximum
Power Dissipation:	6 W Maximum
Environment:	
Ambient Temperature:	0° C to 50° C (32° F to 122° F)
Relative Humidity:	0–90% (non-condensing)
Unibus Unit Load:	1

Table 4-2
MF11-UP Maximum Cycle and Access Times

Bus Mode	Access Time	Cycle Time
DATI	595 ns	1000 ns
DATIP	595 ns	585 ns
DATO-DATOB (Pause L)	150 ns	1000 ns
DATO-DATOB (Pause H)	150 ns	600 ns

4.4 FUNCTIONAL DESCRIPTION

The MF11-UP parity memory is read/write, random access, coincident current, magnetic core, parity memory with a maximum cycle time of 1000 ns and an access time of 585 ns maximum. It is organized in a 3D, 3-wire, planar configuration. Word length is 18 bits, two of which are the parity bits, and the memory capacity is 16,384 (16K) words.

The operation of the parity memory is identical to that of the MF11-U Memory except for the parity generation and checking functions. In order to implement this option, an 18-bit stack module (H217-C) is used (bits 19 and 16 being the parity bits). In addition, a parity controller module is required. The controller is a dual height module (M7259) which plugs into the memory system backplane. It contains a control and status register (CSR) and all the logic used to generate and check parity. A schematic diagram of the parity controller is shown on engineering drawing D-CS-M7259. Odd parity is used; if the number of 1s in a given byte is even, then a 1 will be written into the respective parity bit location. The use of odd parity allows detection of a memory failure of all 0s, which is a more probable failure mode than all 1s.

Error action can be disabled or enabled under program control. If parity error action is enabled by setting bit 0 of the CSR, a parity error will cause assertion of the parity error code on the Unibus. Processors equipped to detect Unibus memory parity errors will trap through vector 114 upon receipt of the parity error code. The error code is BUS PB L asserted and BUS PA L not asserted. (See Paragraph 4.5 in the programming section of this chapter.) On parity generation (DATO or DATOB) both the low order (D00 to D07) and the high order (D08 to D15) bytes are coded. The Unibus data is applied through buffers to the inputs of E4 and E13 on the M7259. The outputs of these ICs will be high if their respective inputs contain an odd number of 1s, and thus cause the D16 or D19 internal parity bits to be set. The D16 bit is the parity bit for the low order byte and the D19 bit is the parity bit for the high order byte. The BUS C1 L signal to the M7259 Parity Controller indicates whether parity is to be generated or checked.

4.4.1 DATI or DATIP Cycle

For parity checking (DATI or DATIP), the same two ICs which were used for parity generation are used; in this case, however, a low input indicates a parity error. During the memory read cycle, the signal Ssyn INT BUS L is sent to the parity controller to indicate that memory data is present on the Unibus. This signal initiates a timing sequence

(PCL SSYN DLY L) to allow for worst case propagation delays of data through the memory data drivers, parity controller data receivers, and the parity tree and checking logic. At the end of this sequence, one of two data input pulses to the parity error flip-flop occur; PC2 PARITY ERROR H or \sim PC2 PARITY ERROR H. If each byte and its respective parity bit contain an odd number of 1s, then \sim PC2 PARITY ERROR H is generated, allowing BUS SSYN to be sent to the bus master to indicate that data is available and valid. If, however, the sum of 1s of either byte is even, then the signal PC2 PARITY ERROR H is generated, causing CSR 15 to set (parity error indication). If parity error action is enabled (CSR0 = 1), then BUS SSYN and BUS PB signals will be enabled. The BUS PB signal indicates to the bus master that a parity error has occurred during the current DATI or DATIP cycle.

Since the restore portion of the memory cycle is skipped during a DATIP operation, provision must be made to save bad data in core in the event of a parity error during DATIP. The operation of the parity controller checking and timing sequence is the same as during a DATI operation, except that if PC2 PARITY ER DLY (0) H is generated, it will cause an 500 ns pulse, DATIP CLR PAUSE (1) L, to be generated. This signal causes the memory to restore the bad data, and also eliminates the requirement for the write cycle which would otherwise have to follow.

4.4.2 DATO Cycle

During a normal DATO cycle, that is, a DATO which does not follow a DATIP, parity is being generated before the read portion of the memory cycle. The Unibus data along with the proper parity bits are transferred into a data register on the G114 Sense Inhibit Module. SSYN is then returned to the bus master via the parity controller to indicate that data has been strobed from the bus. Data is transferred from the data register to core during the write cycle.

If the DATO follows a DATIP, the sequence is altered. During the DATIP, the memory location will have been cleared and a PAUSE flag set. When the DATO occurs, the read cycle will be skipped, and the write cycle begun immediately. The data and parity bits are transferred from their respective buses at the beginning of the write cycle, at which time SSYN is generated.

4.4.3 DATOB Cycle

The DATOB cycle is similar to the DATO, except that during the DATOB, data is written in byte form rather than as a full word. The non-selected byte is simply restored along with the new data in the selected byte plus the parity bits.

4.4.4 Jumper Terminals

The M7259 parity control module contains seven sets of jumper terminals. The physical location of these terminals is shown in Figure 5-14 and the functions of the jumper terminals are listed in Table 4-3.

Table 4-3
M7259 Jumper Terminals

Jumper Terminals	Function
W1-W4	Discrete CSR address
W5	Modifies the timing constant for the SSYN delay one shot multivibrator (always out).
W6	When in, data is restored when a parity error is detected on a DATIP (always in).
W7	When out, SSYN is inhibited and the bus hangs when in the Maintenance Mode (always in).

4.5 PROGRAMMING

The Control and Status Register (CSR) is located on the M7259 Parity Controller. There is one CSR per 32K of memory. Transfer of a 16-bit control word from the processor to the CSR establishes the operating conditions of the MM11-UP. The data format of the CSR is shown below:

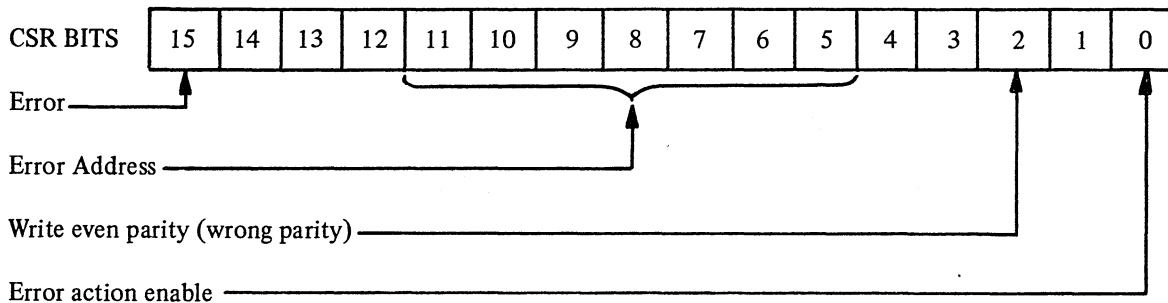

- NOTES:
1. All bits are read/write.
 2. All bits except the error address bits are cleared by INIT.

Bit	Name	Description
15	ERROR	Set when a parity error occurs regardless of whether any other response is enabled. Setting this bit will not cause a parity error trap. This bit is a flag and is not associated with the trap routine.
11:5	ERROR ADDRESS	Contains the highest order address bits of the most recent location causing a parity error.
2	WRITE EVEN PARITY (wrong parity)	Causes the controller to generate incorrect parity on write cycles (DATO or DATOB), forcing a parity error on the next DATI or DATIP cycle. This bit is intended for use as a diagnostic aid.
0	ERROR ACTION ENABLE	Enables error indication to the bus master when set.

The address of the CSR is hardwired in the range 772100 to 772136. Normally, the address 772100 is factory wired for the first 32K increment, 772110 for the second 32K, etc.

4.6 BUS LOADING

An MF11-UP represents two bus loads; one for the MF11-UP 16K Parity Memory Module set and one for the M7259 Parity Controller. The M7259 Parity Controller handles the parity for 32K of memory. A second MM11-UP 16K module set adds one bus load. Therefore, the MF11-UP, expanded to 32K, would represent three bus loads.

4.7 INTERNAL BUS

The internal bus (Figures 4-1 and 4-2) is the communication path between the M7259 Parity Controller and the core memory. It comprises the following signals:

Name	Function
SSYN INT BUS L	Signals the parity controller when data is available on the Unibus to begin parity checking sequence.
PB INT BUS L (D19)	A bidirectional path which carries the generated parity bit to memory on DATO cycles and from memory to the controller on DATI cycles. This is the parity bit for the high order byte (D15:D08).
PA INT BUS L (D16)	Same as PB INT BUS L except that it is the parity bit for the low order byte (D07:D00).
DATIP CLR PAUSE (1) L	Clears the PAUSE flip-flop in the M8293 16K Unibus Timing Module if a parity error occurs on a DATIP cycle, which initiates the write-restore cycle.
DATIP CLR PAUSE L	Not used with the MF11-UP.

4.8 INTERLEAVING RULES FOR PARITY MEMORY

- Both of the memories to be interleaved must be parity memories.
- The two parity memories to be interleaved must cover contiguous address ranges.
- The two parity memories to be interleaved must be in the same backplane.

4.9 CSR ADDRESS SELECTION

The address of the CSR is hardwired in the range of 772100 to 772136. Jumpers W1 through W4 (refer to Figure 5-14 for jumper locations) determine the discrete address.

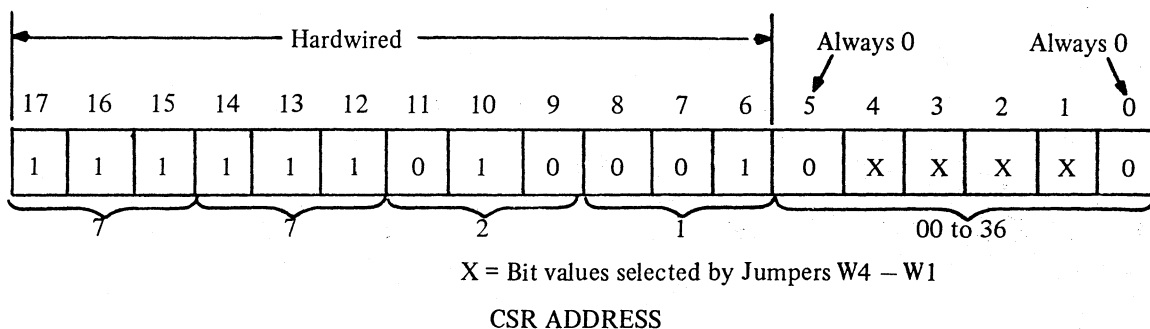

Table 4-4 shows the CSR addresses for all possible memory starting addresses and their jumper configurations. For example, if the lowest address memory responds to is 28K, the jumpers are cut for address 772110. If the lowest address memory responds to is 32K, the jumpers are also cut for address 772110. This is because the CSR addresses are assigned on a basis of 8K of memory. Thus, there are 16 unique addresses in the table.

Table 4-4
 CSR Address Jumper Selection for M7259 Parity Controller
 Module, Etch Rev D, CS Rev E

CSR Jumpers		W4	W3	W2	W1
Bus Address Line		A04	A03	A02	A01
Lower Memory Boundary	CSR Address				
0	772100	X	X	X	X
4K	772102	X	X	X	O
8K	772102	X	X	X	O
12K	772104	X	X	O	X
16K	772104	X	X	O	X
20K	772106	X	X	O	O
24K	772106	X	X	O	O
28K	772110	X	O	X	X
32K	772110	X	O	X	X
36K	772112	X	O	X	O
40K	772112	X	O	X	O
44K	772114	X	O	O	X
48K	772114	X	O	O	X
52K	772116	X	O	O	O
56K	772116	X	O	O	O
60K	772120	O	X	X	X
64K	772120	O	X	X	X
68K	772122	O	X	X	O
72K	772122	O	X	X	O
76K	772124	O	X	O	X
80K	772124	O	X	O	X
84K	772126	O	X	O	O
88K	772126	O	X	O	O
92K	772130	O	O	X	X
96K	772130	O	O	X	X
100K	772132	O	O	X	O
104K	772132	O	O	X	O
108K	772134	O	O	O	X
112K	772134	O	O	O	X
116K	772136	O	O	O	O
120K	772136	O	O	O	O

O = Jumper Removed
 X = Jumper Installed

Example: Assume a starting address of 52K (320000_8) is desired. The example illustrates how the CSR parity address is determined.

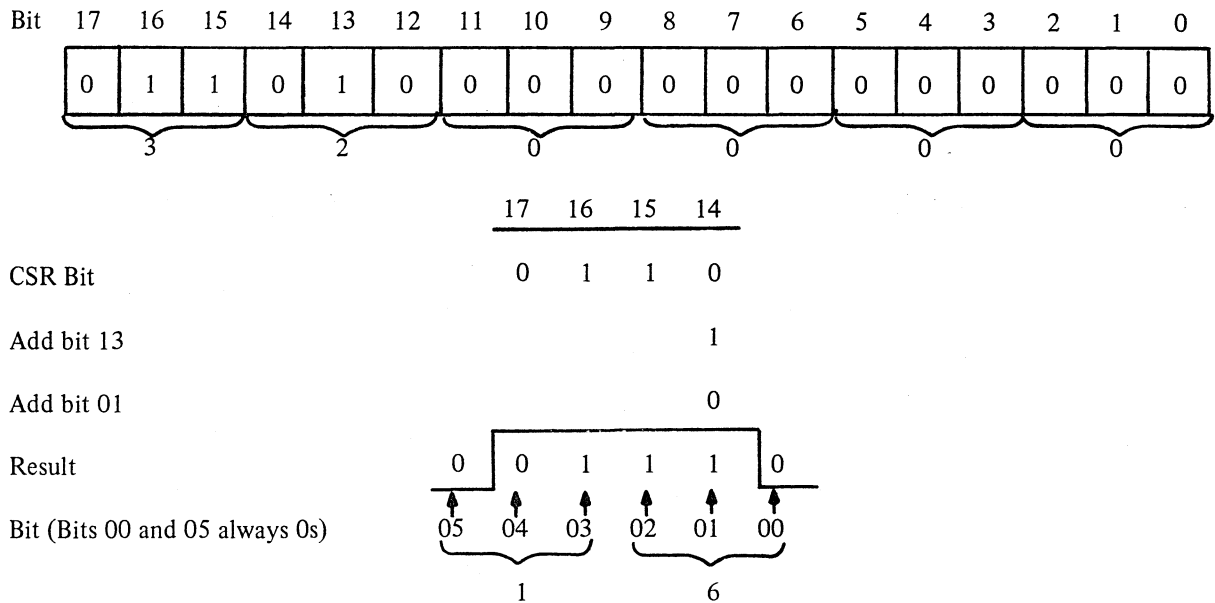

NOTE

When two 16K memories from different backplanes are interleaved, bit A01 is set for the minimum address in one 16K memory and is not set for the minimum address in the other 16K memory.

Address 16 is parity address 772116, since the upper four octal digits are hardwired as 7721XX₈ (Table 4-4). Consequently, for a 52K starting address, the corresponding CSR parity address is 772116 and jumpers W4, W3, and W2 are out (Table 4-4 – W1 is left intact).

When using the algorithm to determine the CSR addresses, one point should be kept in mind. It is assumed that the addresses the memory responds to are contiguous except for interleaving.

Table 4-5 shows the CSR address for each 4K increment of memory. For example, if the lowest address memory responds to is 32K, the parity register address is cut for 772110. If the lowest address memory responds to is 36K the parity register address is also cut for 772110. Consequently, the CSR addresses are assigned on a basis of 8K of memory. Thus, there are 16 unique CSR addresses as shown. The CSR addresses in the table assume the memories are not interleaved or are interleaved within the same backplane. With interleaved memories, the algorithm should be employed to determine the CSR address.

**Table 4-5
CSR Addressing**

Memory Start	Corresponding Parity Register Address
0	772100
4K	772102
8K	772102
12K	772104
16K	772104
20K	772106
24K	772106
28K	772110
32K	772110
36K	772112
40K	772112
44K	772114
48K	772114
52K	772116
56K	772116
60K	772120
64K	772120
68K	772122
72K	772122
76K	772124
80K	772124
84K	772126
88K	772126
92K	772130
96K	772130
100K	772132
104K	772132
108K	772134
112K	772134
116K	772136
120K	772136

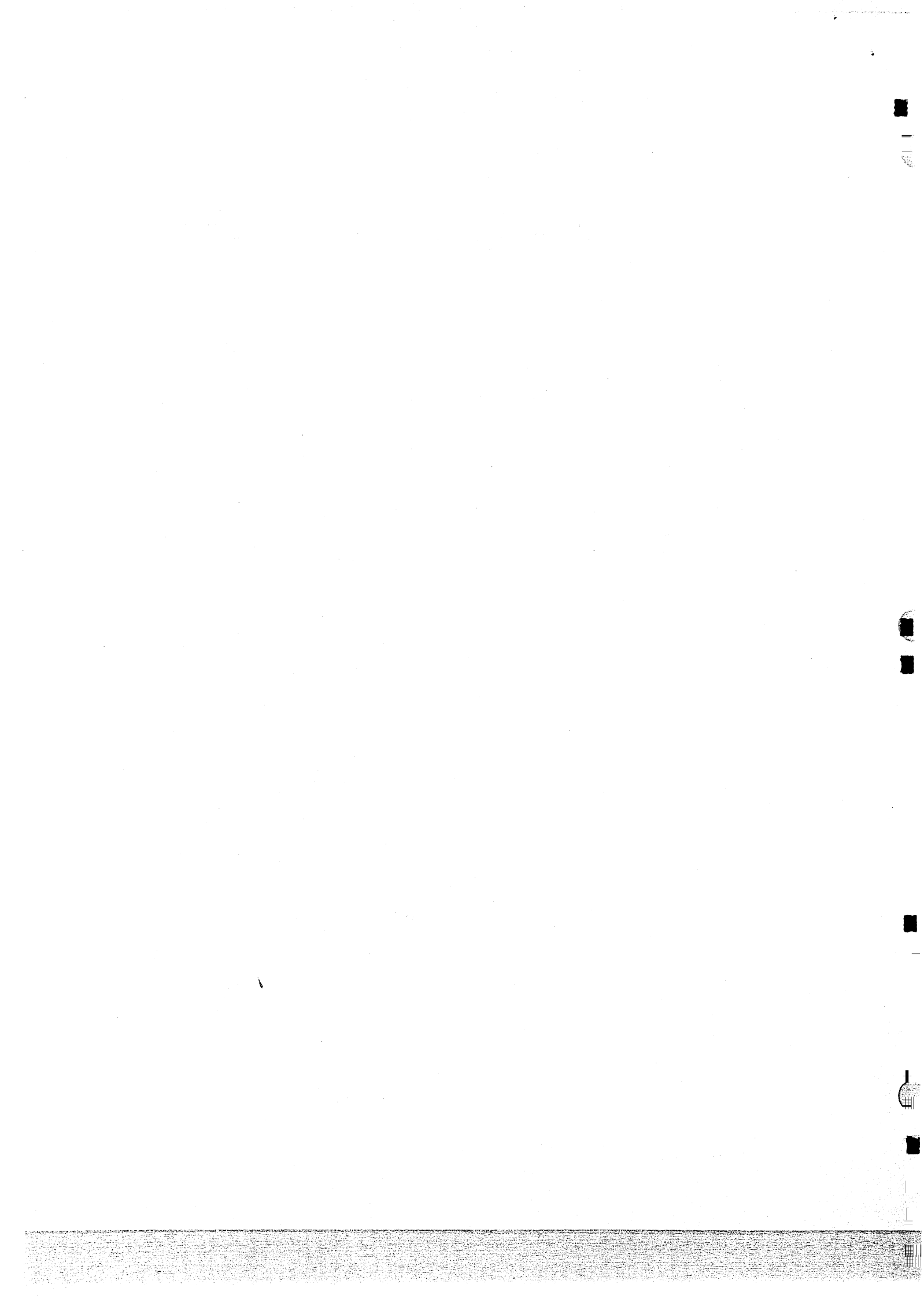

CHAPTER 5

INSTALLATION AND MAINTENANCE

5.1 INTRODUCTION

This chapter discusses the preventive and corrective maintenance procedures that apply to the MF11-U/UP Memory. A major point in the maintenance philosophy of this manual is that the user understand the normal operation of the memory as described in the previous chapters. This knowledge, plus the maintenance information included in this chapter, will aid the user in isolating and correcting malfunctions.

5.2 INSTALLATION

Paragraph 5.2.1 describes the mounting box and power requirements for installing the MF11-U/UP in various equipments. Paragraph 5.2.2 describes the selection of jumpers for the desired memory addressing and the jumper selection for interleaved and non-interleaved operation. The jumpers for the strobe margin and bias current are also described. Paragraph 5.2.3 is a step-by-step procedure for installing the MF11-U/UP as an add-on to an existing system.

5.2.1 Mounting Box and Power System

The MF11-U/UP must be installed in a mounting box capable of holding a PDP-11 double system unit with the facility of +20 V, -5 V, and +5 V power distribution and supplies.

The power distribution systems and cabinets for the PDP-11/40, PDP-11/35, PDP-11/45, PDP-11/50, and the H960-D or -E cabinet with expander box have been revised. Figure 5-1 illustrates how the MF11-U/UP connects with the new revised power distribution system. Figure 5-2 illustrates how the MF11-U/UP connects with the earlier power distribution system.

The MF11-U/UP cannot be used in the CPU cabinet of the earlier version of the PDP-11/45/50 and when the MF11-U/UP is used in the earlier version of either the PDP-11/40/35 or the H960-D/E, an FM11-U field modification kit must be used. When the MF11-U/UP is used in either the earlier or the new system, an H754 regulator must also be used. Each regulator can handle two MF11-U/UP backplanes. Table 5-1 lists each type of equipment and the machine serial numbers that use the new and the earlier power distribution systems. The H754 regulator is included as part of the FM11-U field modification kit, therefore it is not called out in the table when the kit is required.

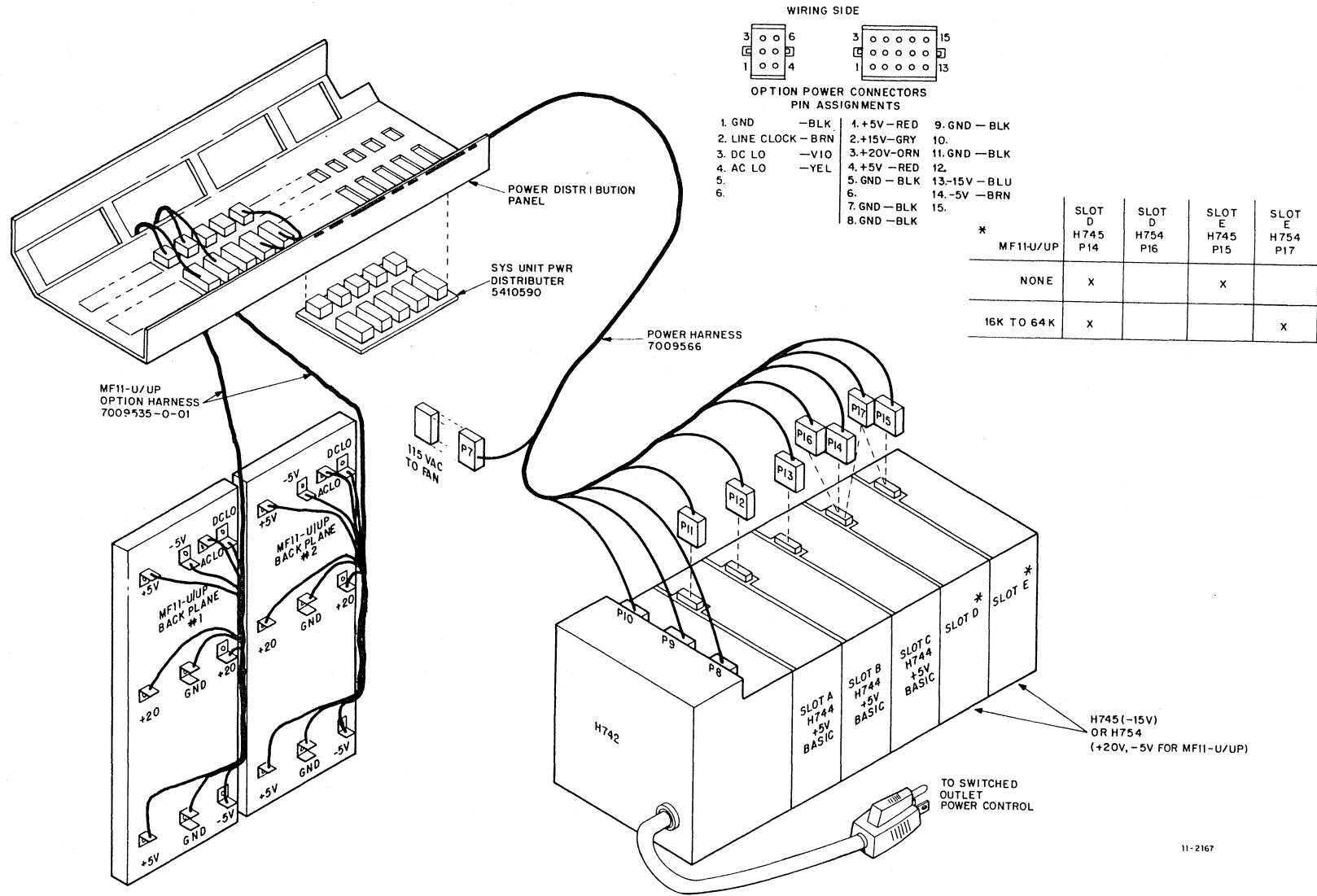

Figure 5-1 New MF11-U Power Distribution System

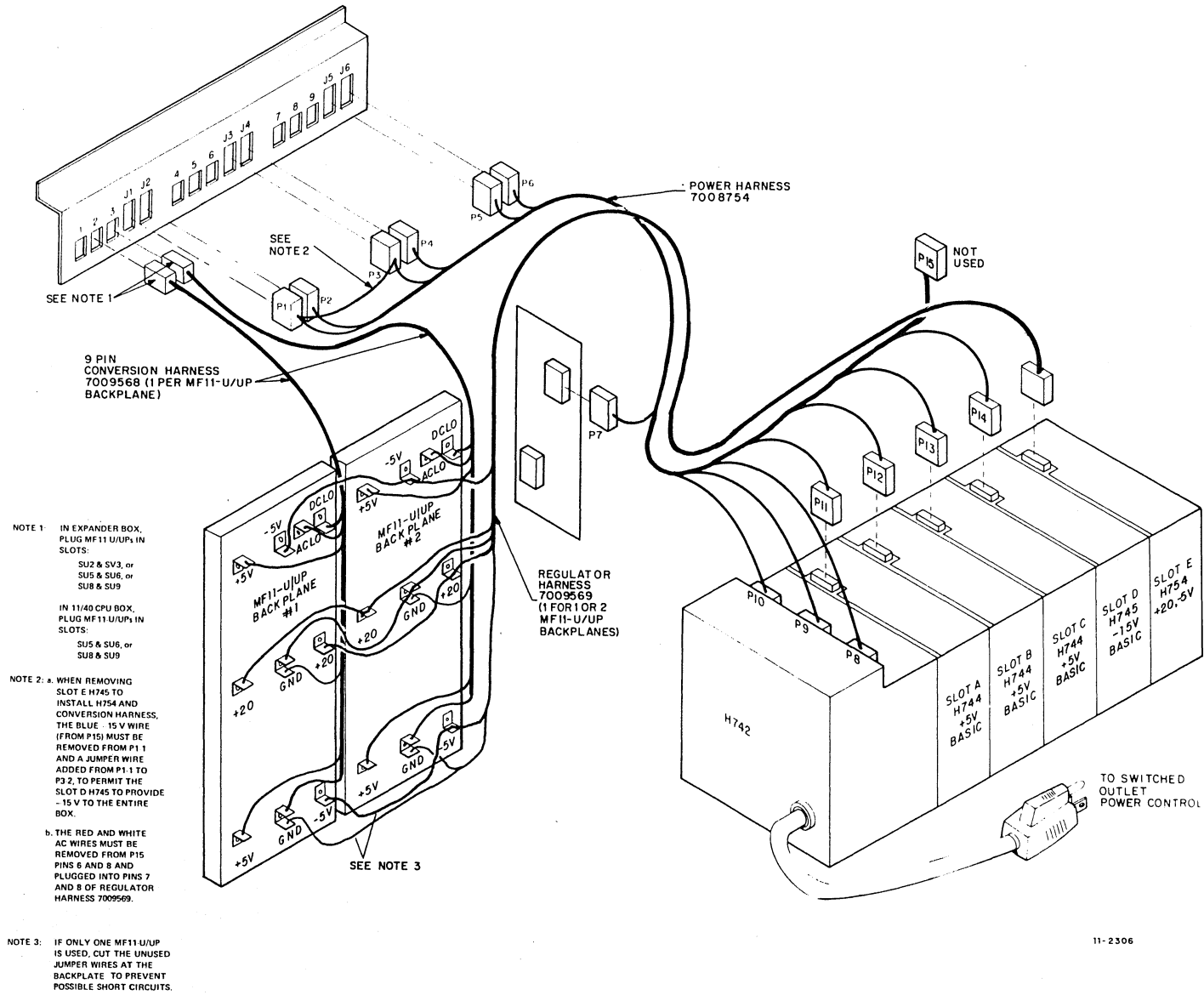

Figure S-2 Early MF11-U Power Distribution System

Table 5-1
Machine Serial Numbers for New and Earlier
Power Distribution Systems

Equipment	Early System	New System
PDP-11/40/35	0 – 5999 FM11-U required	6000 and up H754 required
PDP-11/45/50	0 – 1999 MF11-U/UP can't be used	2000 and up H754 required
H960-D/E	0 – 6999 FM11-U required	7000 and up H754 required

The FM11-U includes a 7009569 conversion harness that must be used between the H754 +20, -5 Vdc regulator and the backplane, and a 7009568 harness which connects the backplane to the Power Distribution Panel (refer to Figure 5-2). One 7009569 harness can power two MF11-U/UP backplanes. If only one is used, the jumpers between backplanes should be cut. One 7009568 harness is required per backplane.

The FM11-U field modification kit permits installation of up to two MF11-U/UP backplanes of 16K memory. It consists of:

- 1 – H754 regulator
- 1 – 7009569 regulator harness
- 2 – 7009568 9-pin conversion harness.

Refer to the field modification kit print set for installation procedures (DD-FM11-U).

5.2.2 Jumper Configuration

The M8293 16K Unibus Timing Module and the G235 Driver Module contain jumper wires. Table 2-4 and Table 2-5 show the jumpers for selecting the device address and for selecting interleaved or non-interleaved operation. The address select jumpers are designated W3 through W7 and the interleaved jumpers are designated W1, W2, W8, W9, and W10 (Paragraph 2.4.3). Both sets of jumpers are located on the M8293 16K Unibus Timing Module.

A second set of jumpers designated W1 through W7 is located on the G235 Driver Module. Jumpers W1 through W4 (sheet DRVA) control the bias current. The cutting of jumpers on the G235 Driver Module is a factory adjustment and should not be changed in the field. The strobe and bias current are set up at the factory with sophisticated test equipment.

The jumpers influence the parameters in a binary-weighted fashion. For the strobe margin, W2 has the least effect, W3 approximately twice the effect of W2, W4 twice the effect of W3, and W1 twice the effect of W4. For the bias current, W6 has the least effect, W7 has twice the effect of W6, and W5 has twice the effect of W7.

5.2.3 Installation Procedure

1. Unpack the MF11-U/UP and remove all packing material.
2. Locate the starting memory address by cutting jumpers W3 through W7 on the M8293 16K Unibus Timing Module (Table 2-4 and 2-5).
3. If interleaved operation is desired, change jumper wires W1, W2, W8, W9, and W10 as described in Paragraph 2.4.3.

CAUTION

Do not tamper with the jumper wires on the G235 Driver Module. These jumpers are preset at the factory and any attempt to change them will result in reduced memory margins and reliability.

4. A backplane jumper is required from B1U1 to B2U1 for non-parity memory. This jumper should not be present for parity memory.
5. For the MF11-UP, ensure that jumpers W6 and W7 are installed on the M7259 Controller Module. Jumpers W1, W2, W3, and W4 should be installed in accordance with Table 4-4.
6. Ensure that the H754 Regulator is installed in the H742 Power Supply, located in the 11/40 or 11/45 processor or expander cabinet. This regulator is necessary for proper operation of the MF11-U/UP. Additional information can be found in the *PDP-11/40 System Manual*, and the *PDP-11/45 and PDP-11/50 System Maintenance Manual*.
7. Ensure that the option power harness is properly connected between the power distribution panel and the backplane.
8. Install backplane assembly in processor mounting box or expander mounting box with four mounting screws.
9. Check backplane assembly for loose or damaged pins.
10. Perform a continuity check between the power supply outputs and ground to ensure that no output voltages are short-circuited.

11. Install modules in accordance with Module Utilization Chart shown in Figure 1-1. Ensure that the modules are firmly seated in the backplane assembly.

NOTE

If only 16K of memory is to be installed, the modules may be placed in the left-hand half or the right-hand half of the backplane assembly. However, the modules should not be interspersed on both halves of the backplane, except for the M7259 Parity Controller, which is located in a fixed position in the backplane. This module should also be at revision E or later.

12. Connect the Unibus cable to the memory. If this is the last device on the bus, the Unibus should be terminated by inserting an M930 Unibus Terminator Module in the BUS OUT slot. If this is not the last device on the bus, the Unibus should be continued by installing an M920 Unibus Jumper Module or the BC11-A Unibus Cable to the BUS OUT slot.

NOTE

If the next device is in the same cabinet, the M920 Unibus Jumper Module can be used.

13. Perform steps 1 through 9 of Paragraph 5.4.1, Voltage Adjustment Procedure.
14. In systems with parity, check and adjust the delay of the PCL SSSYN DLY L signal as described in Paragraph 5.4.2.
15. Load and run all applicable diagnostic programs listed in this chapter. Verify that the program printout agrees with the total memory in the system.

NOTE

The pins listed in steps 16 through 20 are located on the G235 Driver Module of the memory under test (either slot 5 or 6 on the backplane). The two resistors (470 K Ω and 3.9 K Ω) called out are included in the plastic components box of the MM11-U/UP Maintenance Repair Kit.

16. Halt the machine and connect a 470 K Ω resistor between pin AU1 (G2350-0-1, sheet DRVA) and ground. This resistor allows high memory drive current. Load and run the 0-124K Memory Exerciser Diagnostic (MAINDEC-11-DZQMB) using pattern 1. Make two passes.
17. Halt the machine; disconnect the 470 K Ω resistor from pin AU1, and connect it between pin AN2 and ground. This resistor allows low memory drive current. Run two passes of the DZQMB Diagnostic.
18. Halt the machine; disconnect the resistor from pin AN2, and connect a 3.9 K Ω resistor between pin AV1 and ground. This resistor causes SENSE STROBE to occur early. Make two passes with the DZQMB Diagnostic.
19. Halt the machine, disconnect the 3.9 K Ω resistor from ground and connect it between pin AV1 and +5 V. This causes SENSE STROBE to occur late. Make two passes with the DZQMB Diagnostic.
20. Halt the machine; disconnect the resistor and rerun the DZQMB Diagnostic to reverify normal operation.

5.3 PREVENTIVE MAINTENANCE

Preventive maintenance consists of specific tasks performed at intervals to detect conditions that could lead to subsequent performance deterioration or malfunction. The following tasks are considered preventive maintenance items and are recommended to be performed every six months.

- a. Visual inspection
- b. Voltage measurements
- c. Sense strobe delay check
- d. Drive current check
- e. PCL SSSYN DLY check (for parity memories)
- f. Strobe and drive current margins
- g. MAINDEC testing

The two pieces of test equipment recommended for checking and troubleshooting the memory are the Tektronix 453 Dual Trace Oscilloscope or equivalent, and the Weston Schlumberger Model 4443 Digital Voltmeter or equivalent with 0.5 percent accuracy.

CAUTION

Make sure all power is off before installing or removing modules.

5.3.1 Visual Inspection

Visually inspect the modules and backplane for broken wires, connectors, or other obvious defects.

NOTE

All tests and adjustments must be performed in an ambient temperature range of 20° to 30° C (68° to 86° F.)

5.3.2 Voltage Measurements

Turn on the primary power and measure the +20 V, +5 V, and -5 V at the option backplane. All voltages must be within ± 5 percent tolerance.

5.3.3 Sense Strobe Delay Check

To check sense strobe delay, connect channel A of the scope to pin FS1 and channel B to pin CN2 of the G235 Driver Module. The correct delay is 160 ns ± 20 percent after the X read driver (FS1) turns on. Measure the delay from the 5 V point on the falling edge of the waveform at FS1 to the 1.5 V point on the falling edge of the waveform at CN2 as shown in Figure 5-3.

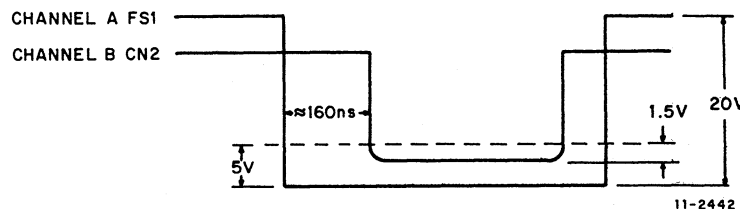

Figure 5-3 Sense Strobe Delay Waveform

5.3.4 Drive Current Checks

Connect a digital voltmeter (Weston Schlumberger Model 4443 or equivalent) between pin AK2 and +5 V on the G235 Driver Module associated with the 16K memory being tested. The drive current is factory-set to provide appropriate drive margins and results in a voltage measurement of 365 mV \pm 15 percent below the +5 V at 25° C (78° F).

5.3.5 PCL SSSYN DLY Check (for parity memories only)

Perform steps 1 through 3 of the adjustment procedure in Paragraph 5.4.3.

5.3.6 Strobe and Drive Current Margins

Perform steps 15 through 20 of the Installation Procedure, Paragraph 5.2.3.

5.3.7 MAINDEC Testing

Load and run for a minimum of two passes all the applicable diagnostic programs listed in Paragraph 5.5. No errors are permitted.

5.4 CORRECTIVE MAINTENANCE

This paragraph describes various adjustment procedures for specific corrective maintenance. It also includes three aids for performing corrective maintenance: a troubleshooting chart, waveforms for the sense inhibit circuits, and waveforms for the drive circuits.

5.4.1 Voltage Adjustment Procedure

1. Power down the equipment.
2. Disconnect the load from the H754 power supply.
3. Power up the equipment.
4. Connect the digital voltmeter to the +20 V and -5 V outputs of the H754.
5. Adjust the +20 V potentiometer R17, located on the side of the H754, for a 25 V reading.
6. Connect the digital voltmeter between the -5 V output and ground.
7. Adjust the -5 V potentiometer R21, located on the top of the H754, for -5 V. This procedure is necessary because the +20 V potentiometer sets the overall output of the regulator (25 V from +20 V to -5 V), while the -5 V adjustment controls the -5 V to ground output. Refer to schematic drawing D-CS-H754-0-1.
8. Power down and then reconnect the load.
9. Power up, recheck the voltages at the option backplane, and if necessary, adjust the outputs again.

5.4.2 Sense Strobe Delay and Drive Current Adjustments

Correction of any failure in either the sense strobe delay or drive current circuits on the G235 module that would require reconfiguration of the jumpers within these circuits should *not* be attempted in the field. Replace the faulty module with a spare G235 module and return the faulty G235 module to the factory for repair.

5.4.3 PCL SSYN DLY L Adjustment Procedure

This adjustment, for systems with parity, sets a 135-ns delay from the leading edge of SSYN INT BUS L to allow sufficient settling time for the parity checking logic. Too long a delay will result in increased cycle time and access time.

1. Load a branch dot instruction with a 000 777 format into an even address within the addressing range of the MF11-UP backplane being checked.
2. Connect channel A of the dual-trace scope to pin B02U1 and channel B to pin A02S2 of the M7259 module.
3. The delay from the 1 V point on the falling edge of the SSYN INT BUS L waveform to the 1 V point on the rising edge of the PCL SSYN DLY L waveform should be 135 ns as shown in Figure 5-4.
4. Adjust R16 on the M7259 module for 135-ns delay.

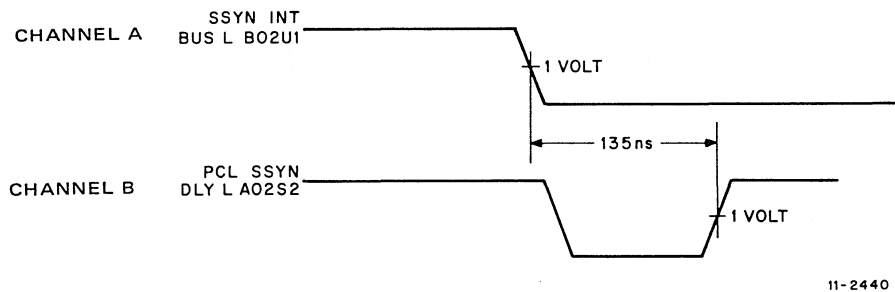

Figure 5-4 SSYN DLY L Timing Waveform

5.4.4 Corrective Maintenance Aids

Figure 5-5 is a troubleshooting chart arranged as a 2-axis grid that identifies fault versus location. Figure 5-6 shows the sense/inhibit circuitry and Figure 5-7 shows the various waveforms associated with the sense/inhibit circuitry. The encircled letters in Figure 5-6 are keyed to the waveforms in Figure 5-7. The drive circuitry is shown in Figure 5-8 and the associated waveforms are shown in Figure 5-9. The encircled letters in Figure 5-8 are keyed to the waveforms indicated in Figure 5-9. Figures 5-10 through 5-13 show the component layout of the MF11-U modules and designate the various functional groupings. Figure 5-14 shows the M7259 Parity Control Module employed with the MF11-UP.

The waveforms are taken in the DATI and DATO modes with worst case memory patterns. They are representative of waveforms taken while running the 0-124K exerciser (DZQMB) with a starting location of 200. Signal MATB A EARLY L at pin CK1 of the M8293 module can be used as a sync signal for the scope. Minor variations in the waveforms may be observed between different memory systems.

5.5 MAINDEC TESTING

Certain DEC programs can be used to test various memory operations as an aid to troubleshooting. The purpose of each of these memory-related test programs, as well as the program abstract, is given in the following paragraphs. Each program contains instructions for use.

5.5.1 0-124K Memory Exerciser (MAINDEC-11-DZQMB)

The purpose of the 0-124K Memory Exerciser program is to test contiguous memory addresses from 000000 to 757776. It verifies that each address is unique (address test) and that each memory location can be read or written reliably (worst case noise test). If memory management is available, all testing is performed with memory management enabled (unless disabled). This program may be used to adjust/margin memory.

5.5.2 0-124K Memory I/O Exerciser (MAINDEC-11-DZQMA)

The purpose of the 0-124K Memory I/O Exerciser is to test sequentially all locations of core memory, or any 4K section of core memory, using any NPR device specified. The program checks bank selection, effective address bits, and memory. It can run stand alone or with a memory management device to access extended memory. Worst case noise patterns are used with the NPR device to test memory. Printouts of NPR device errors are provided and include designation of the device under test, the content of its control and status register, and the content of its error register. Data error printouts include the address of the bad data, the true data sent, and the bad data received.

5.5.3 Combined Parity Memory Tests (MAINDEC-11-DCMFA)

The purpose of the Combined Parity Memory Tests is to locate the parity memory registers and perform a check of the bits in each. A map showing the memory controlled by each parity register is created by the program. The parity registers and memory are tested using the information in the map.

Several bit patterns are written into each parity memory location to ensure that no parity errors are created. Each byte of parity memory is written with both good and bad parity to ensure that the parity bits can be toggled and sensed.

Failure Symptom	Loc.	Possible Circuit
Memory Does Not Respond to MSYNL	C	-5.1V
Memory Hangs Bus	C	Device Selection or Jumpers
DATO Fails	C	DELAY Flip-Flop or DELAY Line
DATIP Fails	C	Read Lockout Flip-Flop
Many Bits Fail	C	SSYN Flip-Flop
Picks Bits	C	PAUSE Flip-Flop
Drops Bits	C	SENSE STROBE H
Byte Failures	C	CLEAR MIR L
4 Bits Fail	C	CLK MIR H
2 Bits Fail	C	INHIBIT TIME H
1 Bit Fails	C	OUTPUT ENABLE H
Fails All Addresses	C	INIT L Circuit
A1-A3 Common	D	Bus Receiver Driver
A4-A6 Common	C	Sense Amplifier or Terminator
A7-A9 Common	C	Data Latch
A10-A13 Common	C	Inhibit Driver
READ Waveforms Wrong	C	17 mV Threshold
WRITE Waveforms Wrong	S	Stack S/I Line
No Inhibit	S	Stack X-Y Line
	S	Stack Diode
	S	Stack Thermistor
	D	X-Y Volt Reference Circuit
	D	Stack Discharge Circuit
	D	X I Generator
	D	Y I Generator
	D	YDR
	D	YSS
	D	XDR
	D	XSS
	D	READ/WRITE Timing Signals
	D	DC LO L Circuit
		Backplane
		+5V
		+20V

Location { C = G114 Sense Control
S = Stack
D = G235 Driver

X = Indicates Circuit Not Operable
Lo = Measured Parameter Too Low or Early
Hi = Measured Parameter Too High or Late

Figure 5-5 Troubleshooting Chart

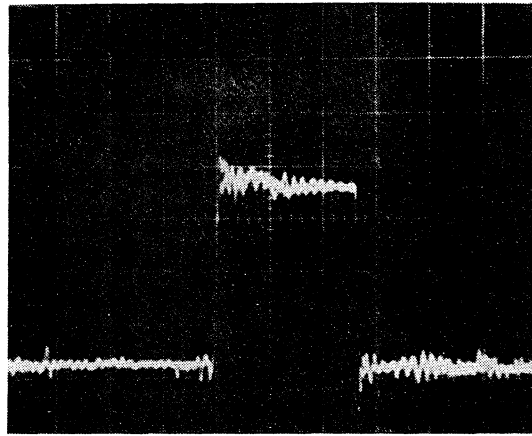

A

1 V/cm
100 ns/cm

GND

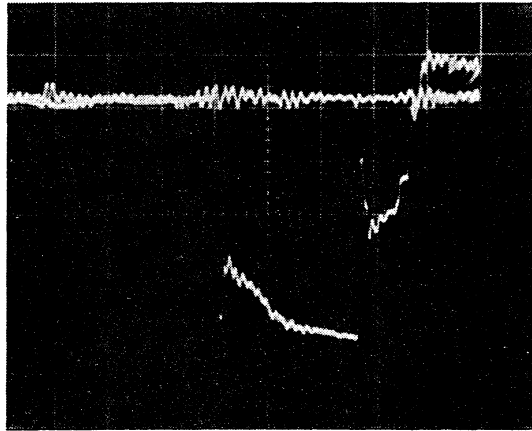

B

1 V/cm
100 ns/cm

GND

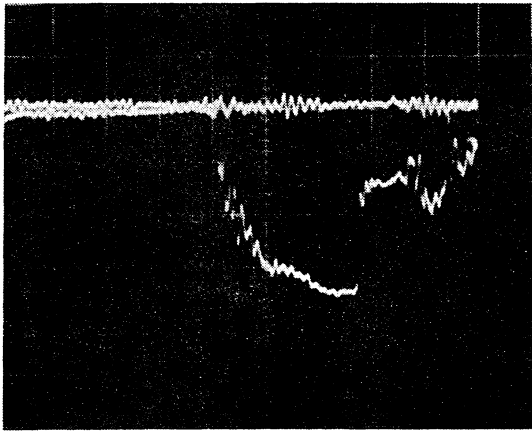

C

1 V/cm
100 ns/cm

GND

Figure 5-7 Sense Inhibit Module Waveforms (Sheet 1 of 4)

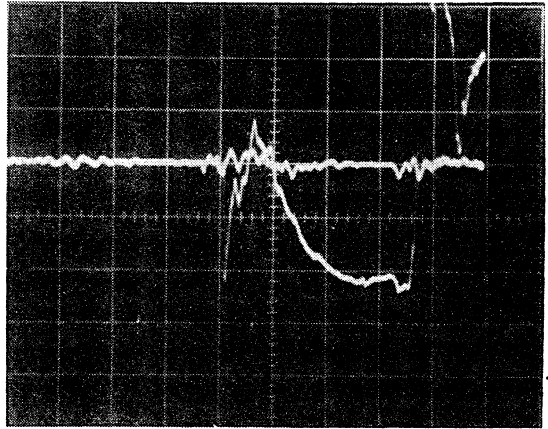

D

5 V/cm
100 ns/cm

GND

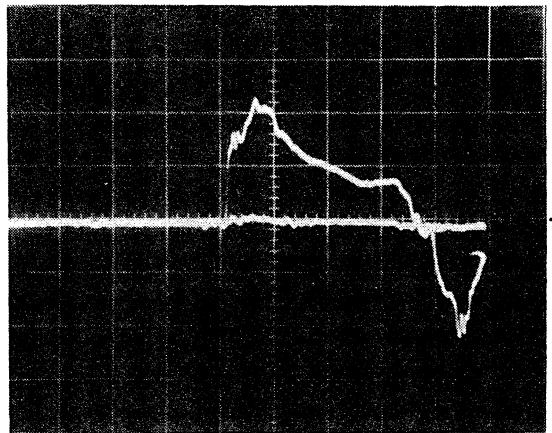

E

10 V/cm
100 ns/cm

GND

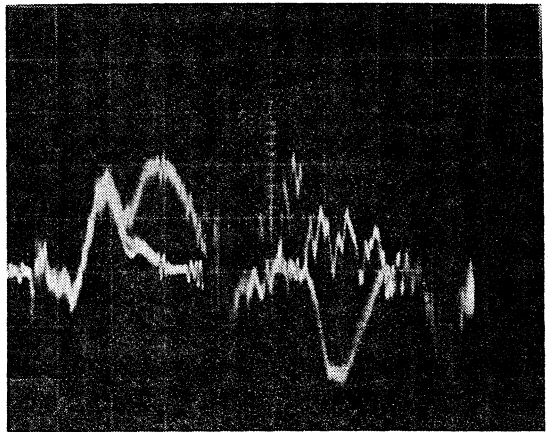

F, G

20 V/cm
100 ns/cm

Figure 5-7 Sense Inhibit Module Waveforms (Sheet 2 of 4)

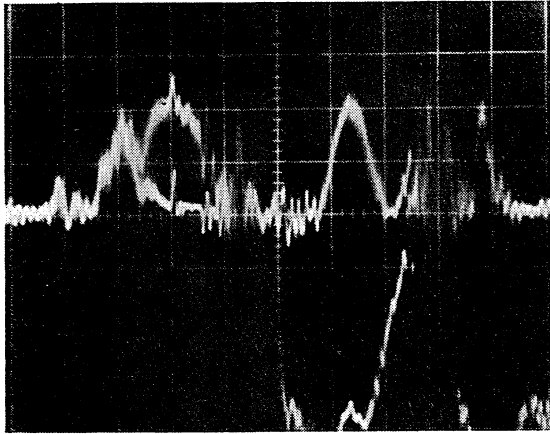

H

20 mV/cm
100 ns/cm

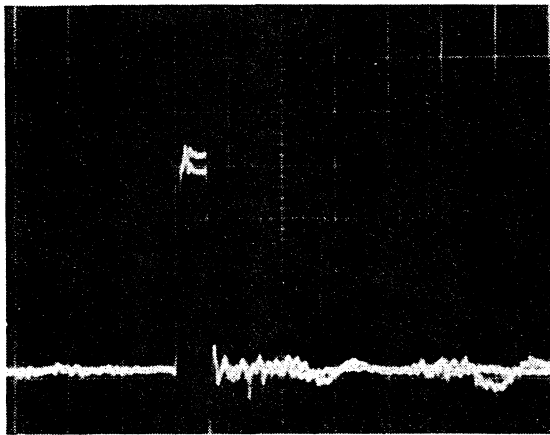

I

1 V/cm
100 ns/cm

GND

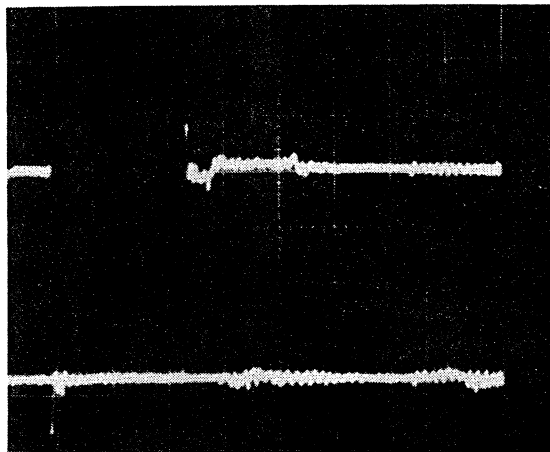

J

1 V/cm
100 ns/cm

GND

Figure 5-7 Sense Inhibit Module Waveforms (Sheet 3 of 4)

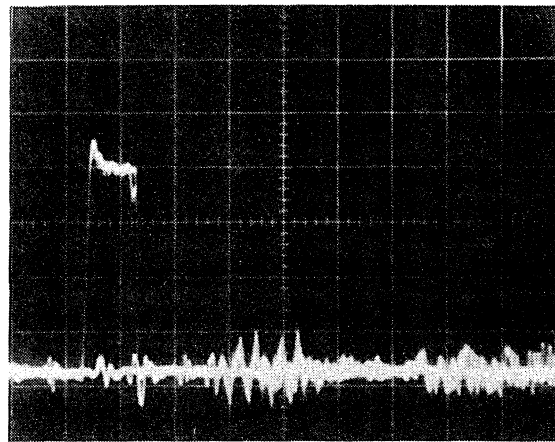

K

1 V/cm
100 ns/cm

— GND

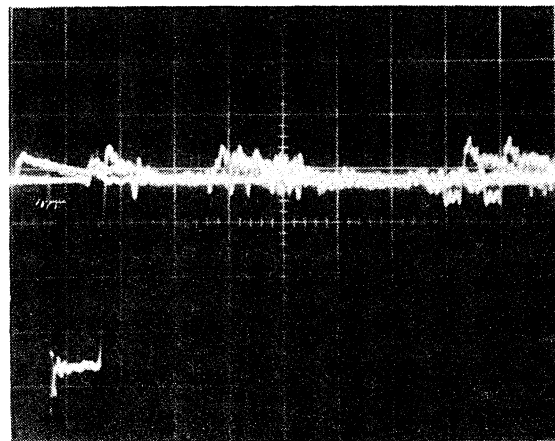

L

1 V/cm
100 ns/cm

— GND

Figure 5-7 Sense Inhibit Module Waveforms (Sheet 4 of 4)

S-17

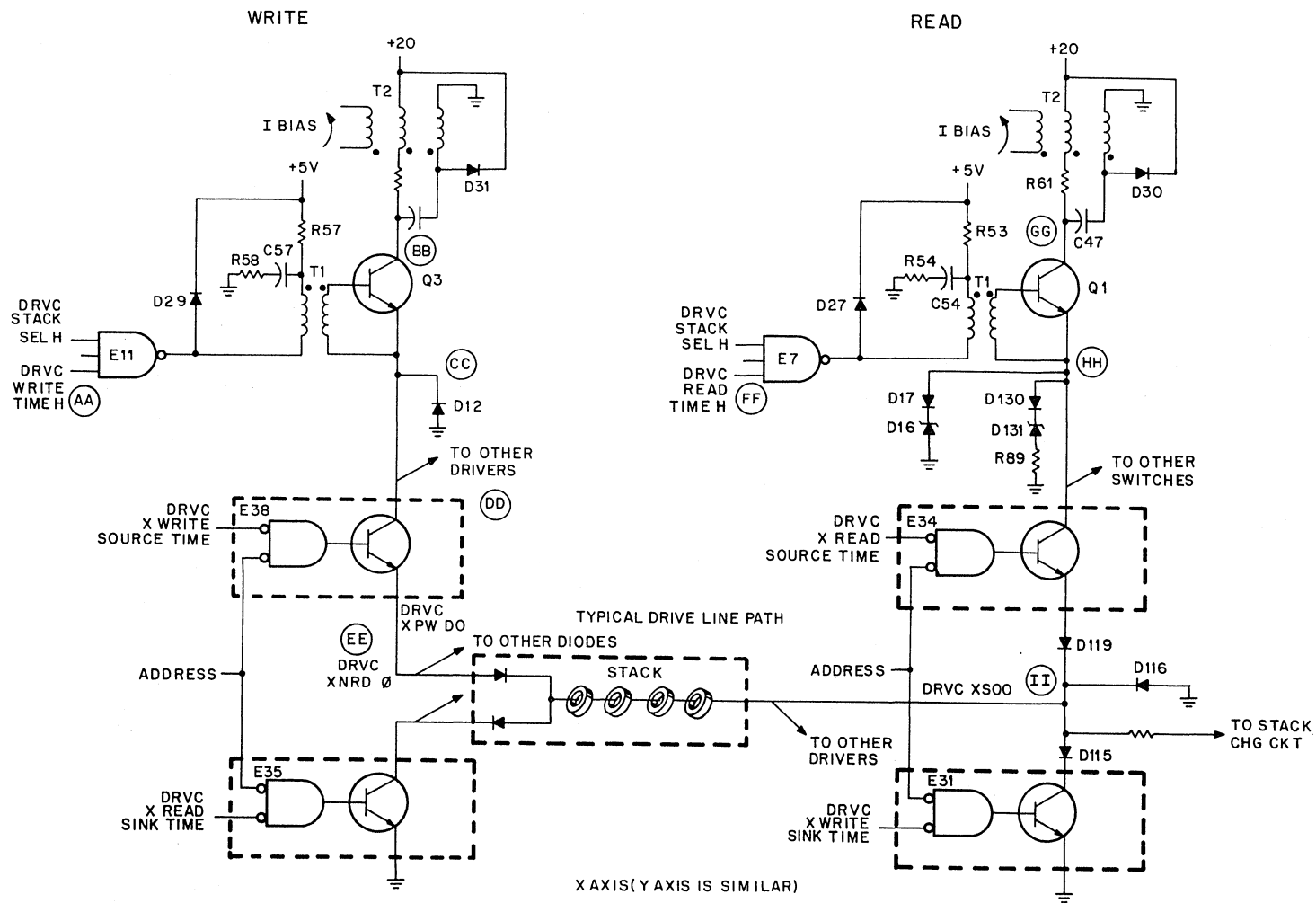

11-1795

Figure 5-8 Typical Read/Write Drive Circuit

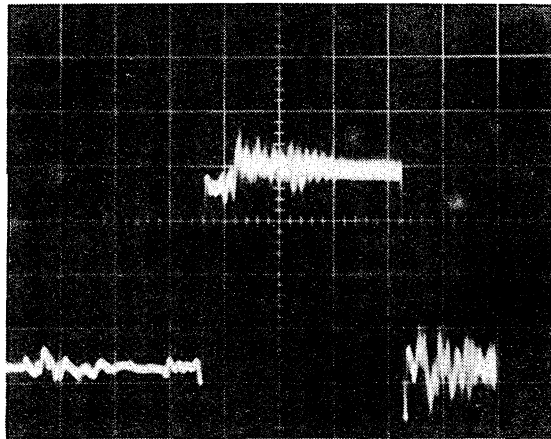

AA

1 V/cm
100 ns/cm

GND

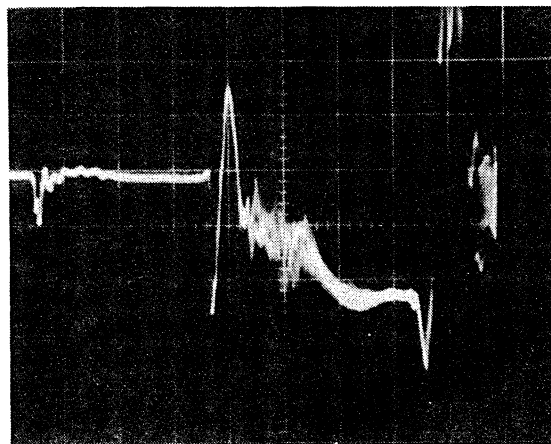

BB

5 V/cm
100 ns/cm

GND

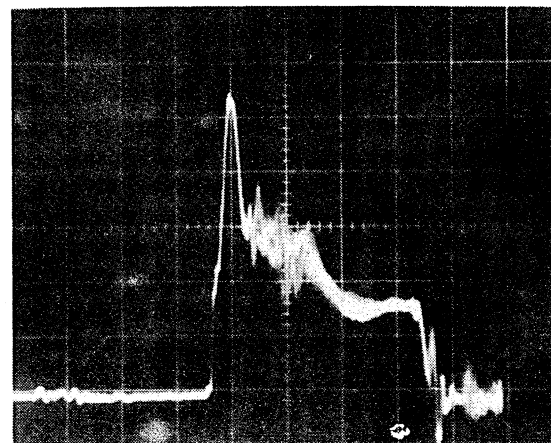

CC

5 V/cm
100 ns/cm

GND

Figure 5-9 Drive Module Waveforms (Sheet 1 of 3)

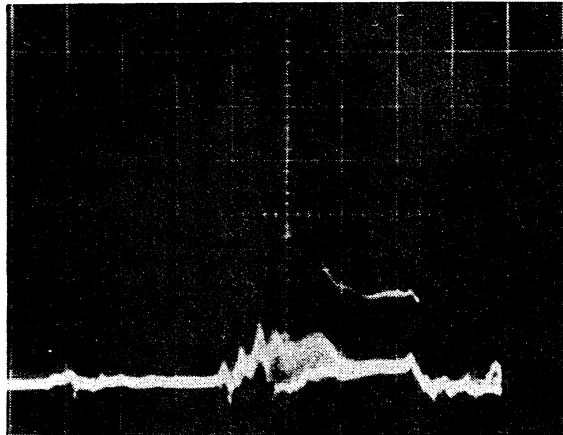

DD

5 V/cm
100 ns/cm

GND

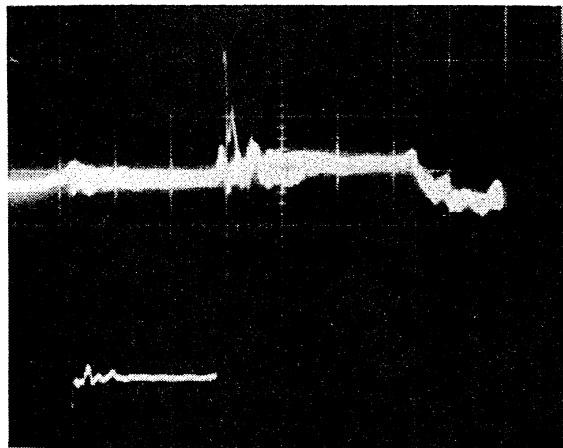

EE

5 V/cm
100 ns/cm

GND

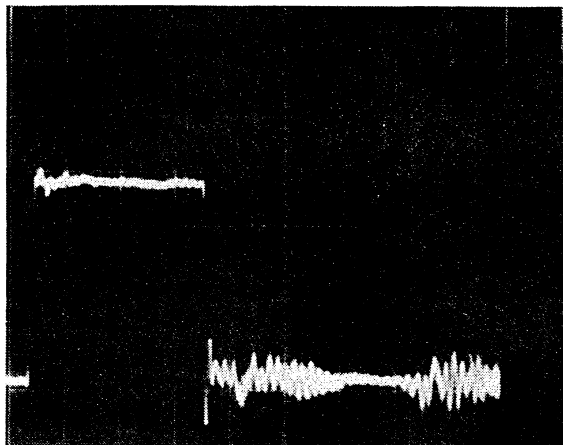

FF

1 V/cm
100 ns/cm

GND

Figure 5-9 Drive Module Waveforms (Sheet 2 of 3)

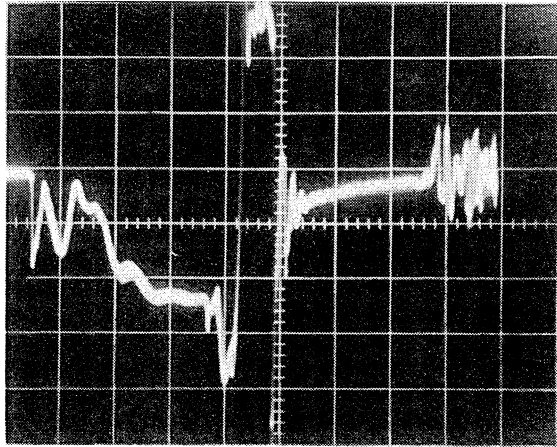

GG

5 V/cm
100 ns/cm

— GND

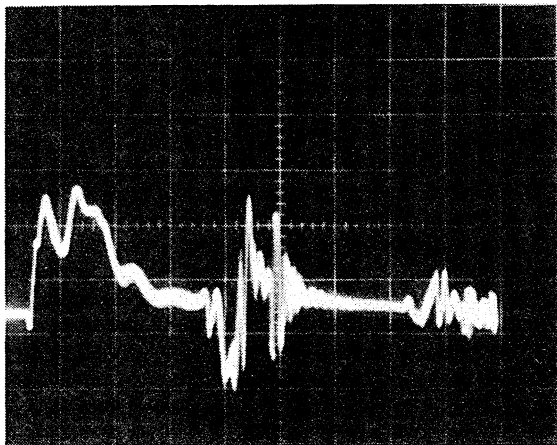

HH

5 V/cm
100 ns/cm

— GND

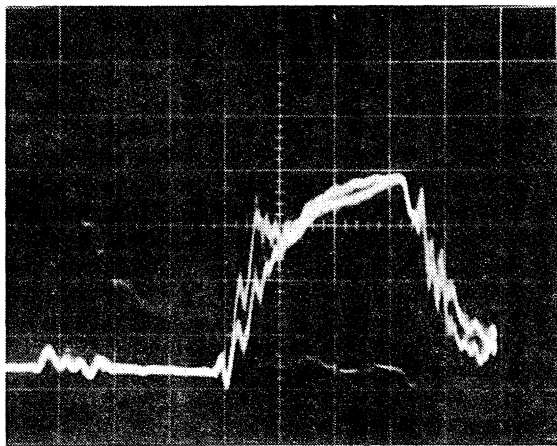

II

5 V/cm
100 ns/cm

— GND

Figure 5-9 Drive Module Waveforms (Sheet 3 of 3)

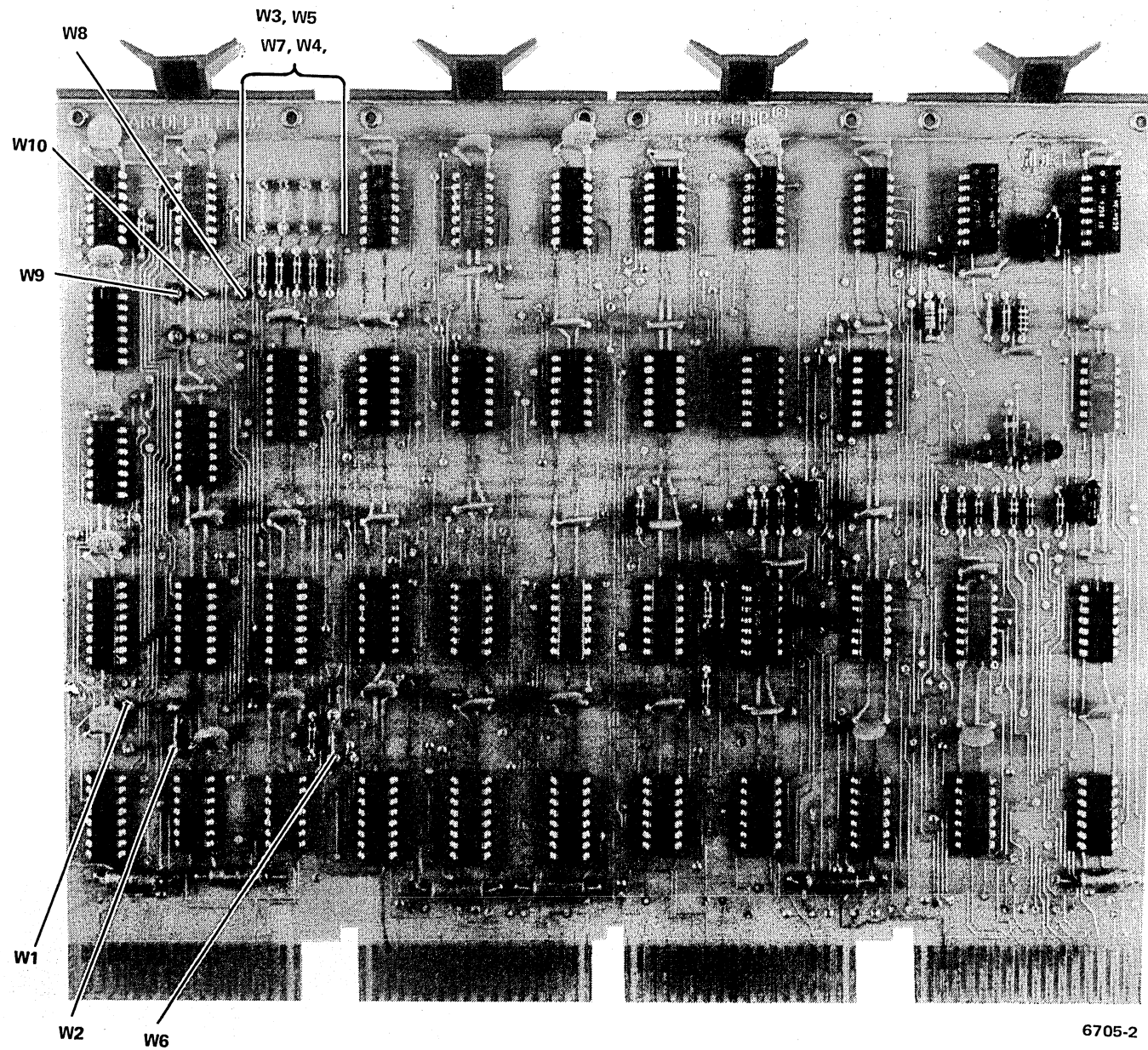

NOTE: W1, W2, W8, W9,
and W10 ARE SELECTED
FOR INTERLEAVED OR
NON-INTERLEAVED
OPERATION'
W3, W4, W5, W6, and W7
ARE SELECTED FOR
STARTING ADDRESS
REFER TO PRINT MATA
FOR JUMPER CONFIG-
URATION

5-21

6705-2

Figure 5-10 M8293 16K Unibus Timing Module

5-22

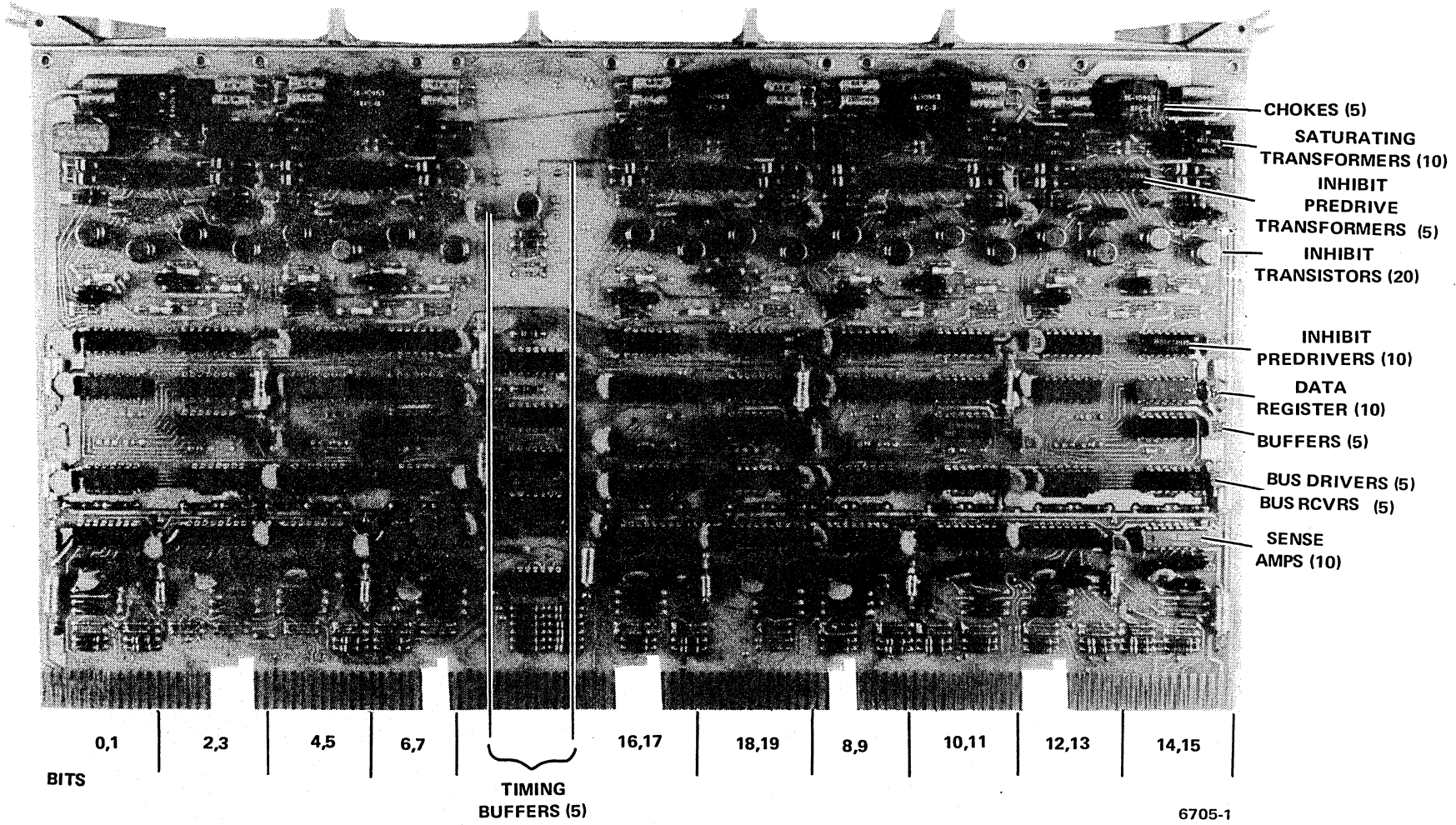
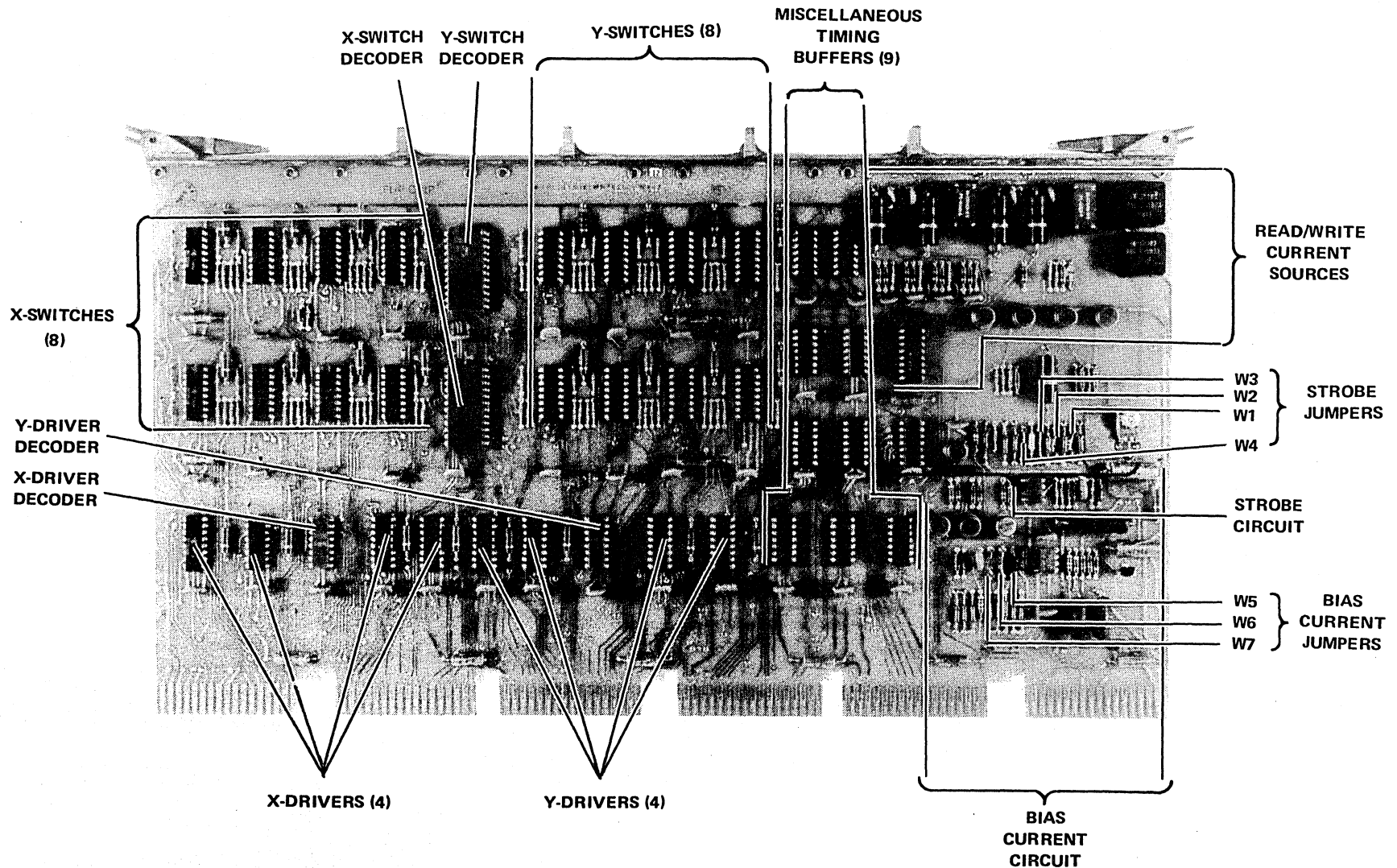

Figure 5-11 G114 Sense Inhibit Module

5-23



NOTE: REFER TO PRINT DRVA FOR ELECTRICAL CONFIGURATION OF JUMPERS.

6642-2

Figure 5-12 G235 X-Y Driver Module

S-24

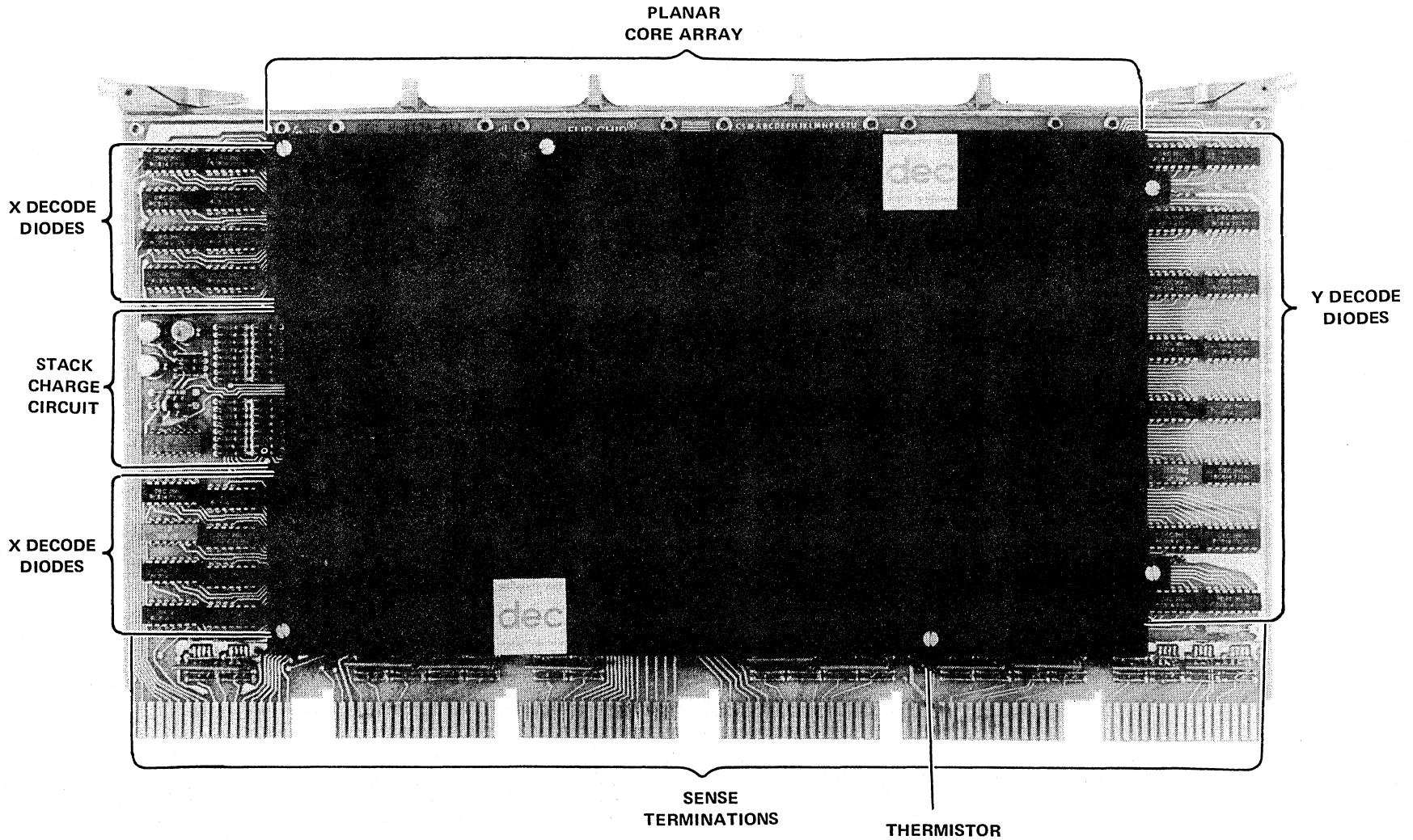

6642-3

Figure 5-13 H217 Stack Module

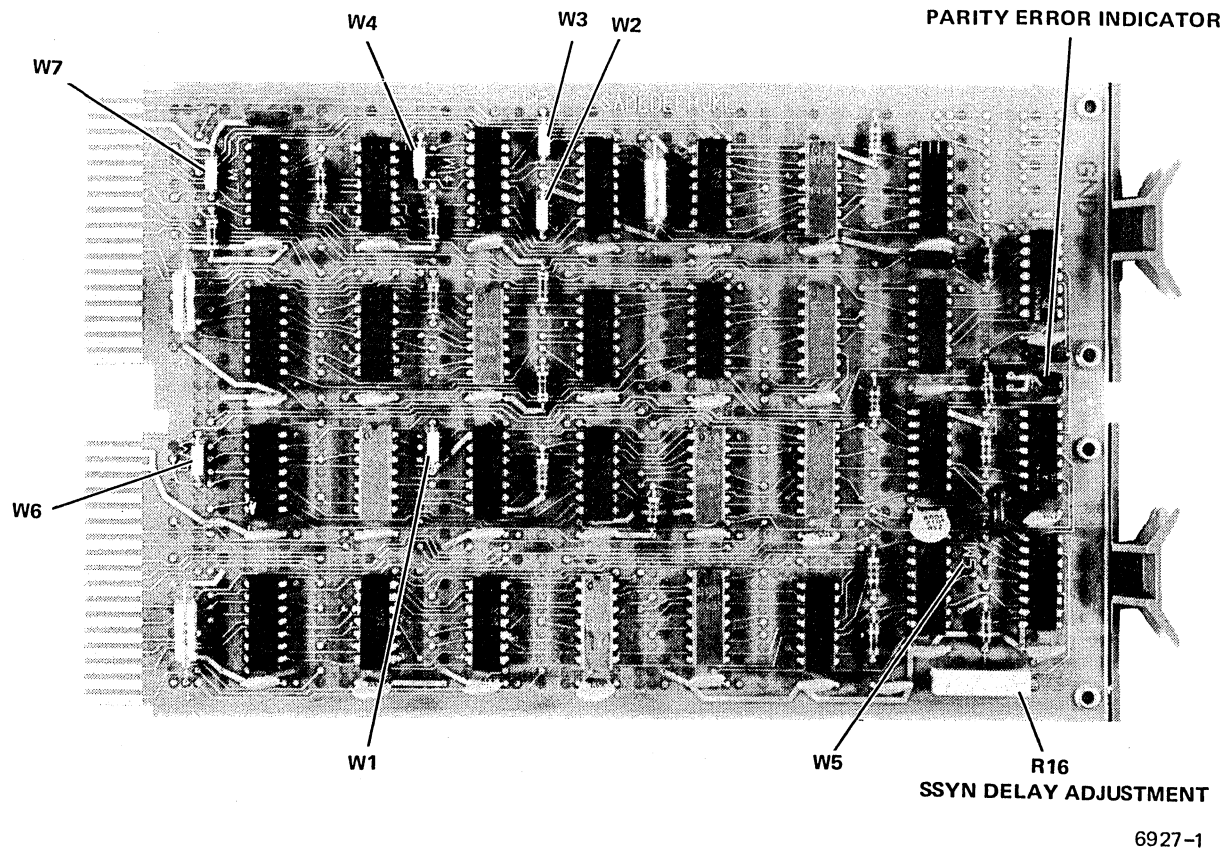
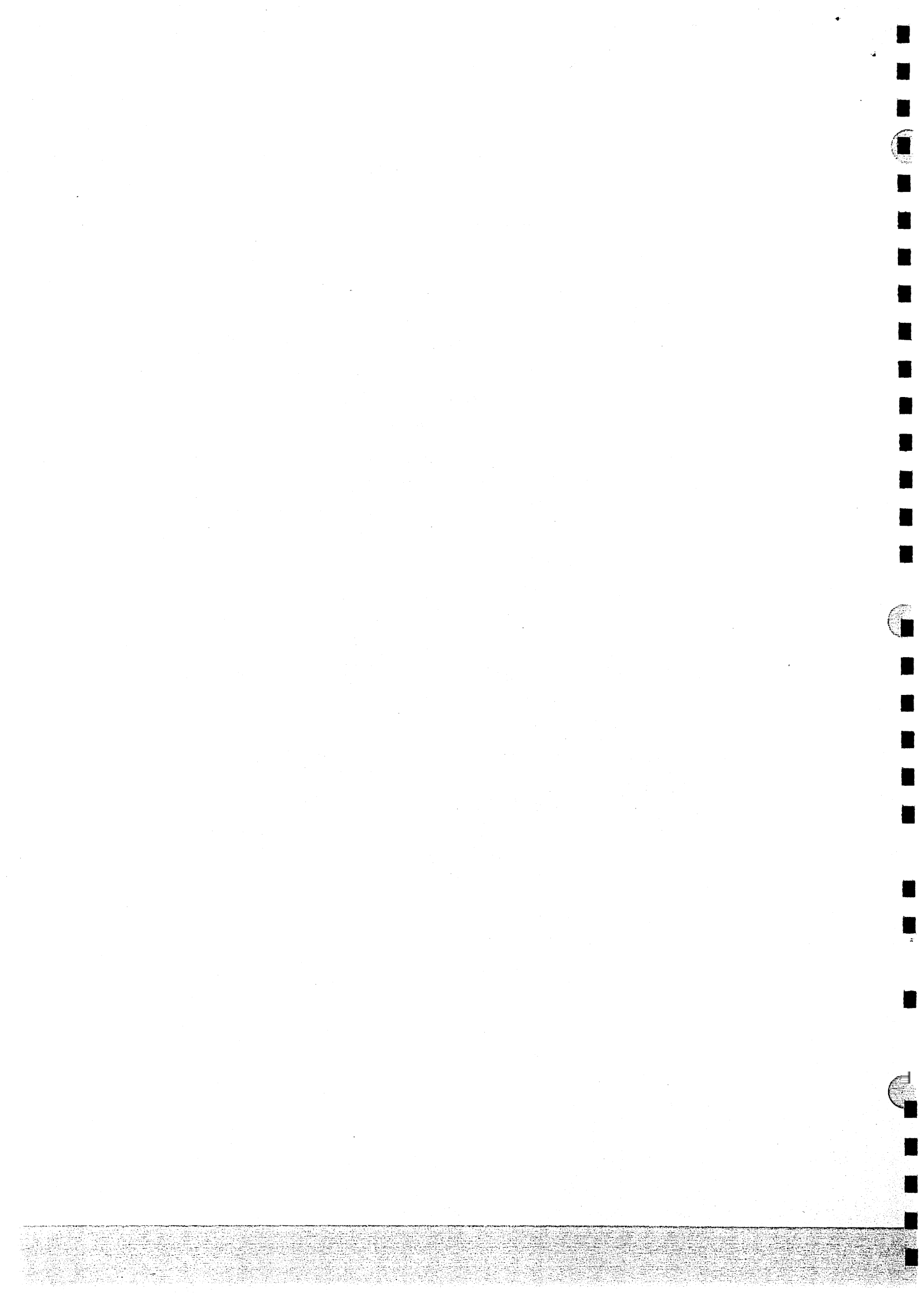

Figure 5-14 M7259 Parity Control Module



APPENDIX A
IC DESCRIPTIONS

A.1 741 HIGH PERFORMANCE OPERATIONAL AMPLIFIER

The 741 Operational amplifier is a high performance amplifier featuring offset-voltage null capability. The devices are short circuit protected and the internal frequency compensation ensures stability without external components.

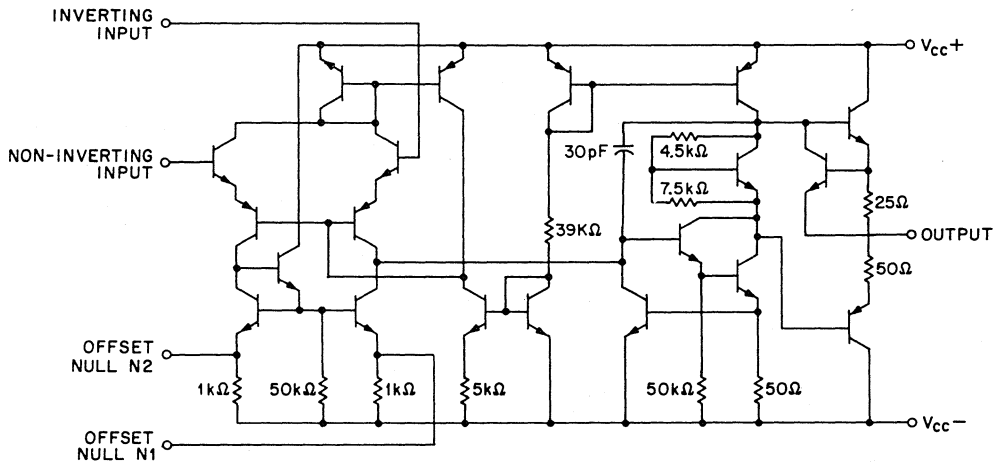

NOTE:
Component values shown are nominal.

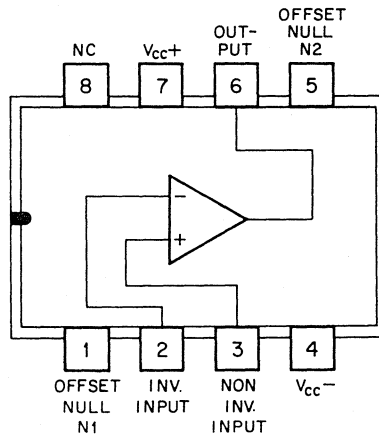

11-2138

A.2 7442 4 LINE TO 1 LINE DECODER

These BCD-to-decimal decoders consist of eight inverters and ten 4-input NAND gates. The inverters are connected in pairs to make BCD input data available for decoding by the NAND gates.

TRUTH TABLES

BCD Input				Decimal Output									
D	C	B	A	0	1	2	3	4	5	6	7	8	9
0	0	0	0	0	1	1	1	1	1	1	1	1	1
0	0	0	1	1	0	1	1	1	1	1	1	1	1
0	0	1	0	1	1	0	1	1	1	1	1	1	1
0	0	1	1	1	1	1	0	1	1	1	1	1	1
0	1	0	0	1	1	1	1	0	1	1	1	1	1
0	1	0	1	1	1	1	1	1	0	1	1	1	1
0	1	1	0	1	1	1	1	1	1	0	1	1	1
0	1	1	1	1	1	1	1	1	1	1	0	1	1
1	0	0	0	1	1	1	1	1	1	1	1	0	1
1	0	0	1	0	1	1	1	1	1	1	1	1	0
1	0	1	0	1	1	1	1	1	1	1	1	1	1
1	0	1	1	0	1	1	1	1	1	1	1	1	1
1	1	0	0	1	1	1	1	1	1	1	1	1	1
1	1	0	1	0	1	1	1	1	1	1	1	1	1
1	1	1	0	0	1	1	1	1	1	1	1	1	1
1	1	1	0	1	1	1	1	1	1	1	1	1	1
1	1	1	1	0	1	1	1	1	1	1	1	1	1
1	1	1	1	0	1	1	1	1	1	1	1	1	1
1	1	1	1	1	1	1	1	1	1	1	1	1	1

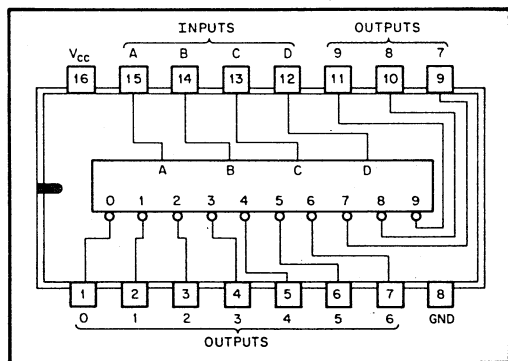

11-0733

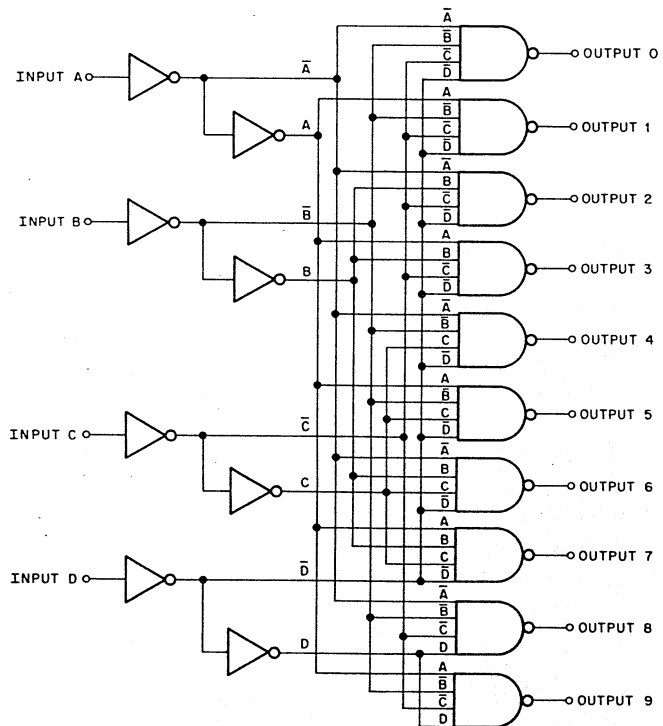

11-0734

Parameter		MIN	TYP	MAX	Unit
t_{pd0}	Propagation delay time to logical 0 level through two logic levels	10	22	30	ns
t_{pd0}	Propagation delay time to logical 0 level through three logic levels		23	35	ns
t_{pd1}	Propagation delay time to logical 1 level through two logic levels	10	17	25	ns
t_{pd1}	Propagation delay time to logical 1 level through three logic levels		26	35	ns

A.3 7475 4-BIT BISTABLE LATCH

The 7475 latches are used for temporary storage of binary information. Information present at a data (D) input is transferred to the Q output when the clock is high, and the Q output will follow the data input as long as the clock remains high. When the clock goes low, the information (present at the data input at the time of the transition) is retained at the Q output until the clock is permitted to go high.

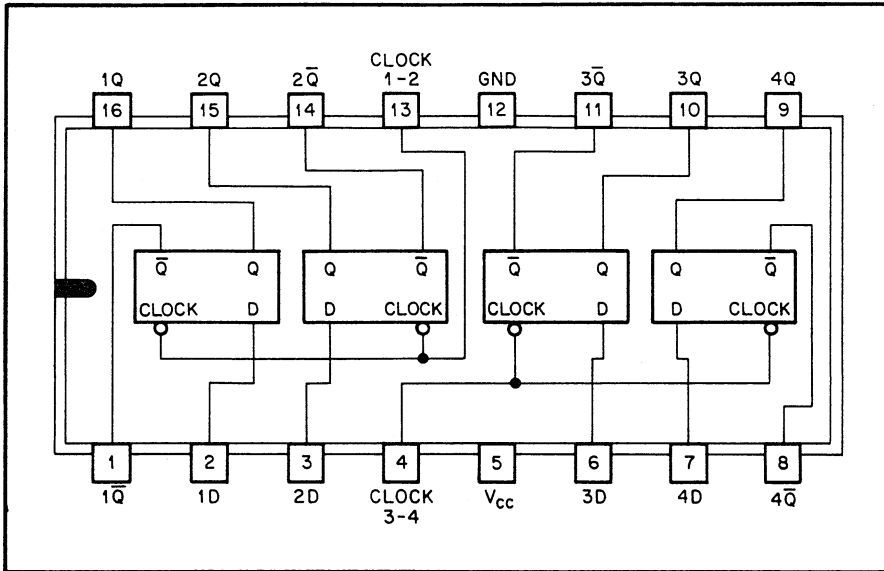

**Truth Table
(Each Latch)**

t_n	t_{n+1}
D	Q
1	1
0	0

NOTES:

1. t_n = bit time before clock negative-going transition.
2. t_{n+1} = bit time after clock negative-going transition.

11-0894

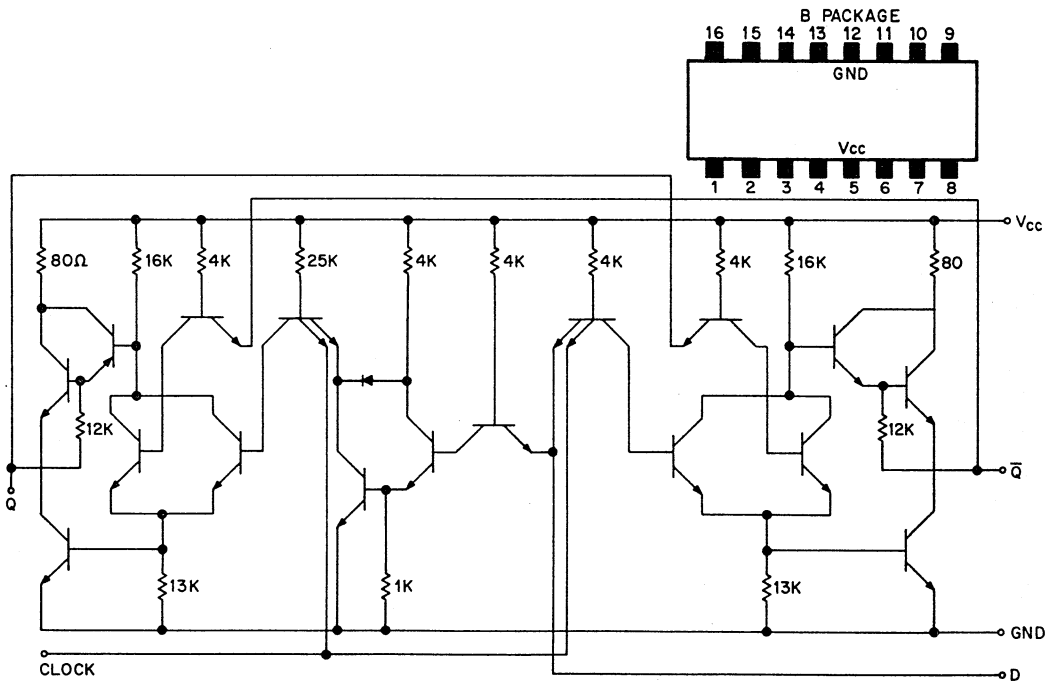

11-0468

Parameter		MIN	TYP	MAX	Unit
t_{setup1}	Minimum logical 1 level input setup time at D input		7	20	ns
t_{setup0}	Minimum logical 0 level input setup time at D input		14	20	ns
t_{hold1}	Maximum logical 1 level input hold time required at D input	0	15¶		ns
t_{hold0}	Maximum logical 0 level input hold time required at D input	0	6¶		ns
$t_{\text{pd1(D-Q)}}$	Propagation delay time to logical 1 level from D input to Q output		16	30	ns
$t_{\text{pd0(D-Q)}}$	Propagation delay time to logical 0 level from D input to Q output		14	25	ns
$t_{\text{pd1(D-}\bar{\text{Q}})}$	Propagation delay time to logical 1 level from D input to $\bar{\text{Q}}$ output (SN5475, SN7475)		24	40	ns
$t_{\text{pd0(D-}\bar{\text{Q}})}$	Propagation delay time to logical 0 level from D input to $\bar{\text{Q}}$ output (SN5475, SN7475)		7	15	ns
$t_{\text{pd1(C-Q)}}$	Propagation delay time to logical 1 level from clock input to Q output		16	30	ns
$t_{\text{pd0(C-Q)}}$	Propagation delay time to logical 0 level from clock input to Q output		7	15	ns
$t_{\text{pd1(C-}\bar{\text{Q}})}$	Propagation delay time to logical 1 level from clock input to $\bar{\text{Q}}$ output (SN5475, SN7475)		16	30	ns
$t_{\text{pd0(C-}\bar{\text{Q}})}$	Propagation delay time to logical 0 level from clock input to $\bar{\text{Q}}$ output (SN5475, SN7475)		7	15	ns

¶ These typical times indicate that period occurring prior to the fall of clock pulse (t_0) below 1.5 V when data at the D input will still be recognized and stored.

A.4 7483 4-BIT BINARY ADDER

The 7483 Binary Adder adds two 4-bit binary numbers. The sum outputs are provided for each bit and the resultant carry is obtained from the fourth bit.

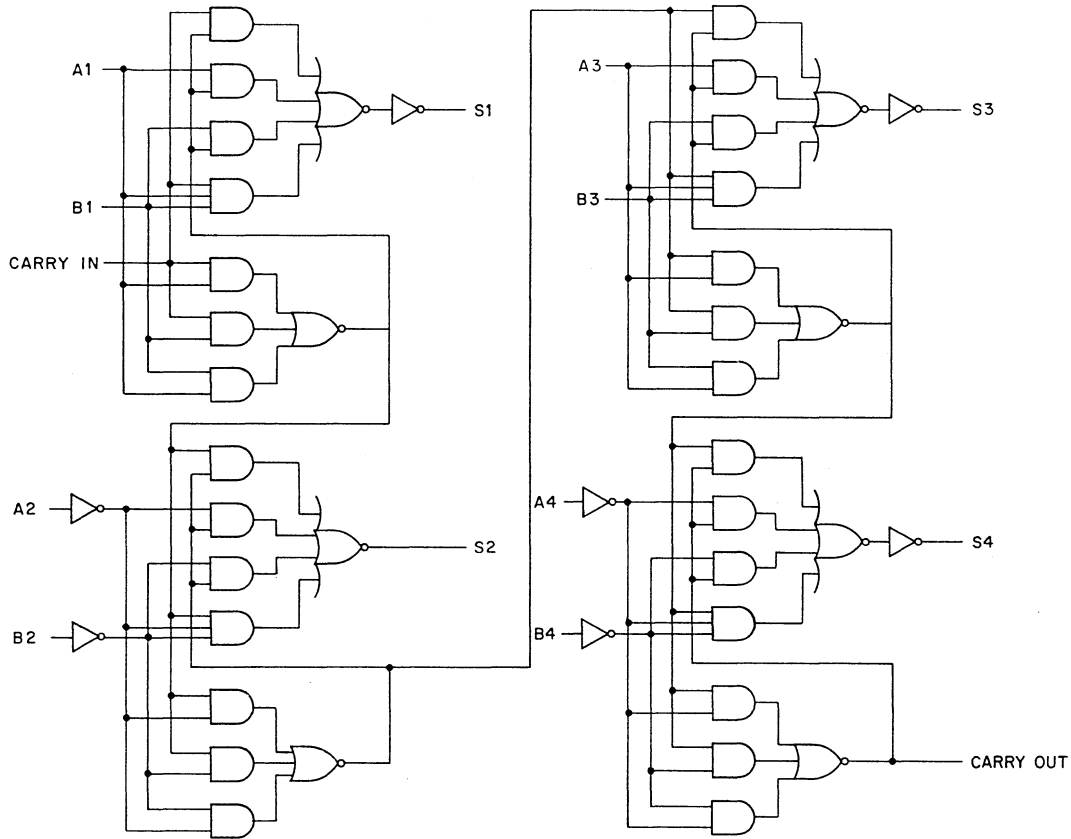

LOGIC DIAGRAM

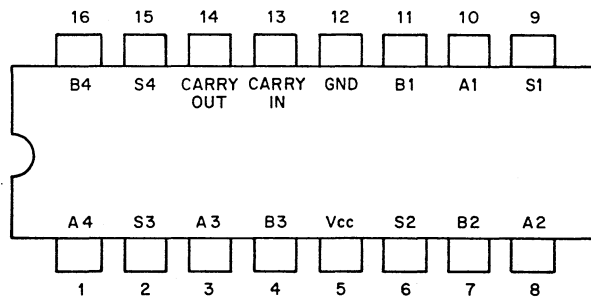

PIN LOCATOR
(TOP VIEW OF IC)

8E-0130

Input				Output					
				When $C_0 = 0$			When $C_0 = 1$		
				When $C_2 = 0$			When $C_2 = 1$		
A_1 A_3	B_1 B_3	A_2 A_4	B_2 B_4	Σ_1 Σ_3	Σ_2 Σ_4	C_2 C_4	Σ_1 Σ_3	Σ_2 Σ_4	C_2 C_4
0	0	0	0	0	0	0	1	0	0
1	0	0	0	1	0	0	0	1	0
0	1	0	0	1	0	0	0	1	0
1	1	0	0	0	1	0	1	1	0
0	0	1	0	0	1	0	1	1	0
1	0	1	0	1	1	0	0	0	1
0	1	1	0	1	1	0	0	0	1
1	1	1	0	0	0	1	1	0	1
0	0	0	1	0	1	0	1	1	0
1	0	0	1	1	1	0	0	0	1
0	1	0	1	1	1	0	0	0	1
1	1	0	1	0	0	1	1	0	1
0	0	1	1	0	0	1	1	0	1
1	0	1	1	1	0	1	0	1	1
0	1	1	1	1	0	1	0	1	1
1	1	1	1	0	1	1	1	1	1

NOTE: 1. Input conditions at $A_1, A_2, B_1, B_2,$ and C_0 are used to determine outputs Σ_1 and Σ_2 , and the value of the internal carry C_2 . The values at $C_2, A_3, B_3, A_4,$ and B_4 , are then used to determine outputs $\Sigma_3, \Sigma_4,$ and C_4 .

Parameters§	From (Input)	To (Output)	MIN	TYP	MAX	Unit
t_{pd1}	C_0	1			34	ns
t_{pd0}					40	ns
t_{pd1}	C_0	2			38	ns
t_{pd0}					42	ns
t_{pd1}	C_0	3			50	ns
t_{pd0}					60	ns
t_{pd1}	C_0	4			55	ns
t_{pd0}					55	ns
t_{pd1}	C_0	C_4		35	48	ns
t_{pd0}				22	32	ns
t_{pd1}	A_2 or B_2	2			40	ns
t_{pd0}					35	ns
t_{pd1}	A_4 or B_4	4			40	ns
t_{pd0}					35	ns

§ t_{pd1} is propagation delay time to logical 1 level. t_{pd0} is propagation delay time to logical 0 level.

A.5 7485 4-BIT COMPARATOR

The 7485 performs magnitude comparison of straight binary or straight BCD codes. Three fully decoded decisions ($A > B$, $A < B$, $A = B$) about two 4-bit words (A,B) are made and externally available at three outputs.

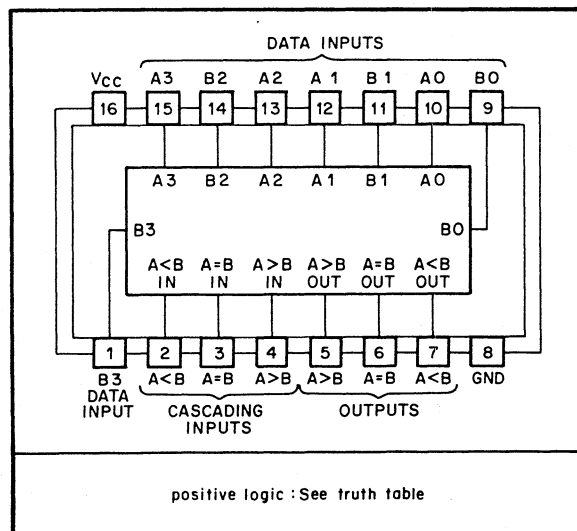
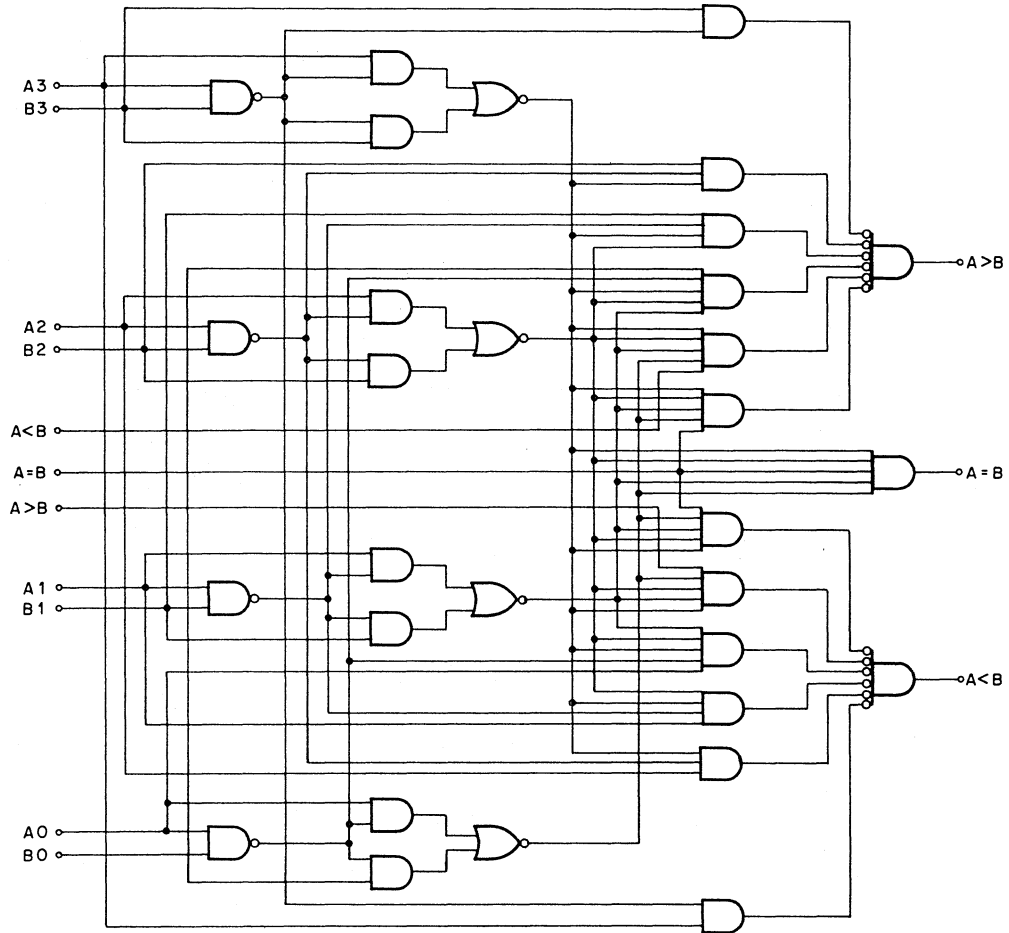

[†] Pin assignments for these circuits are the same for all packages.

TRUTH TABLE

COMPARING INPUTS				CASCADING INPUTS			OUTPUTS		
A3, B3	A2, B2	A1, B1	A0, B0	A > B	A < B	A = B	A > B	A < B	A = B
A3 > B3	X	X	X	X	X	X	H	L	L
A3 < B3	X	X	X	X	X	X	L	H	L
A3 = B3	A2 > B2	X	X	X	X	X	H	L	L
A3 = B3	A2 < B2	X	X	X	X	X	L	H	L
A3 = B3	A2 = B2	A1 > B1	X	X	X	X	H	L	L
A3 = B3	A2 = B2	A1 < B1	X	X	X	X	L	H	L
A3 = B3	A2 = B2	A1 = B1	A0 > B0	X	X	X	H	L	L
A3 = B3	A2 = B2	A1 = B1	A0 < B0	X	X	X	L	H	L
A3 = B3	A2 = B2	A1 = B1	A0 = B0	H	L	L	H	L	L
A3 = B3	A2 = B2	A1 = B1	A0 = B0	L	H	L	L	H	L
A3 = B3	A2 = B2	A1 = B1	A0 = B0	L	L	H	L	L	H

NOTE: H = high level, L = low level, X = irrelevant

Parameter	MIN	TYP	MAX	Unit
t _{PLH} Propagation delay time, low-to-high-level output, from any A or B input		90	150	ns
t _{PHL} Propagation delay time, high-to-low-level output, from any A or B input		75	150	ns
t _{PLH} Propagation delay time, low-to-high-level output, from A > B, A < B, or A = B inputs		75	150	ns
t _{PHL} Propagation delay time, high-to-low-level output, from A > B, A < B, or A = B inputs		55	100	ns

A.6 7528 SENSE AMPLIFIER

The 7528 integrated circuit contains two dc coupled single-preamplifier sense amplifiers. The output of each preamplifier is available as a test point. These test points can be used to observe the amplified core signal to facilitate accurate strobe timing. Avoid coupling the strobe signal or other stray signals to the test point and also avoid excessive loading of the test point.

Waveforms F and G in Figure 5-8 (schematic shown in Figure 5-7) are the input waveshapes and waveform H is the output waveshape for a typical sense/inhibit line.

TRUTH TABLE

INPUTS		OUTPUT
A	S	W
H	H	H
L	X	L
X	L	L

DEFINITION OF LOGIC LEVEL

INPUT	H	L	X
A†	$V_{ID} > V_T \text{ MAX}$	$V_{ID} < V_T \text{ MIN}$	IRRELEVANT
S	$V_I > V_{IH} \text{ MIN}$	$V_I < V_{IL} \text{ MAX}$	IRRELEVANT

†A is a differential voltage (V_{ID}) between A1 and A2. For these circuits V_{ID} is considered positive regardless of which terminal is positive with respect to the other.

II-1122

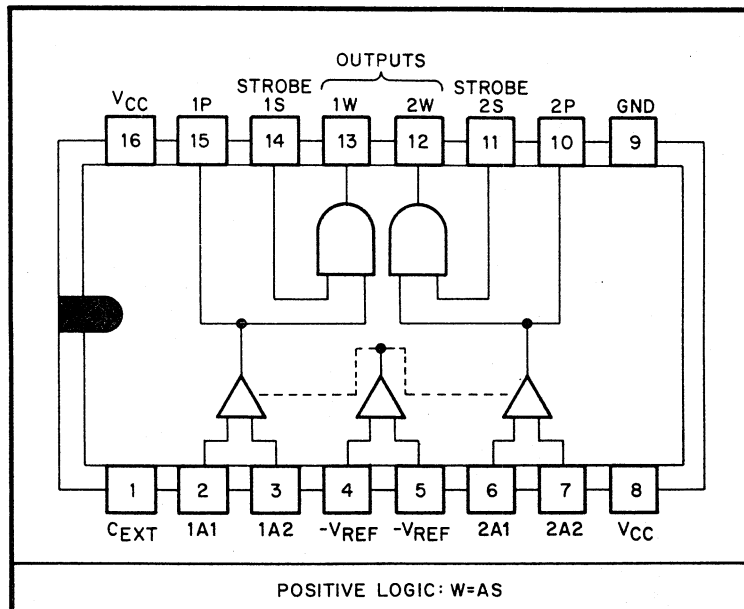

Propagation Delay Times			MIN	TYP	MAX	Unit
Symbol	From Input	To Output				
$t_{PLH(D)}$	A1-A2	W		25	40	ns
$t_{PHL(D)}$					20	
$t_{PLH(S)}$	STROBE	W		15	30	ns
$t_{PHL(S)}$					20	

t_{PLH} - propagation delay time - low level input to high level output

t_{PHL} - propagation delay time - high level input to low level output

(D) -

(S) -

A.7 82S62 9-BIT PARITY GENERATOR AND CHECKER

The 82S62 Parity Generator/Checker has two outputs (EVEN and ODD) and an INHIBIT input that disables both outputs. A logic 1 on the INHIBIT input forces both outputs to logic 0. When used as a parity generator, the 82S62 supplies a parity bit which is transmitted with the data word. At the receiving end, the 82S62 can be used as a parity checker to indicate that data has been received correctly or that an error has been detected.

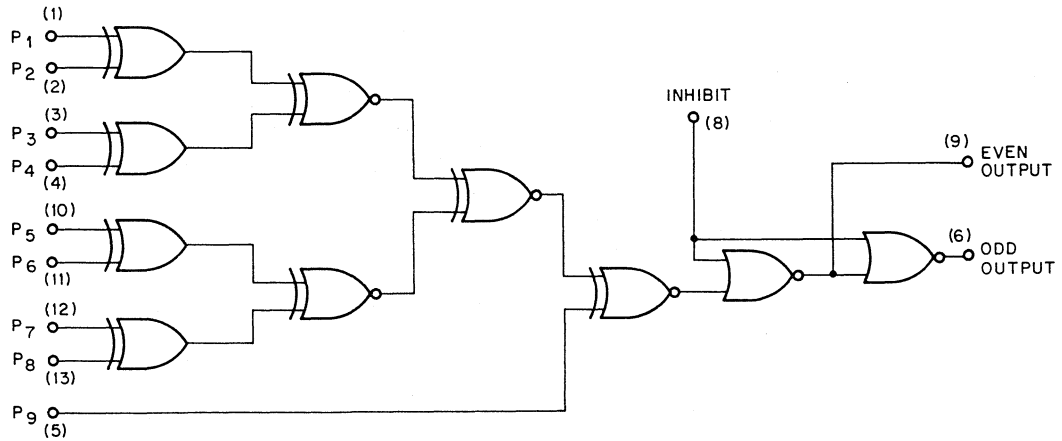

NOTES:

1. V_{CC}=(14)
2. GND=(7)
3. () = denotes pin number, pin numbers shown for Dual in-line package only
4. ODD OUTPUT =
 $P_1 \oplus P_2 \oplus P_3 \oplus P_4 \oplus P_5 \oplus P_6 \oplus P_7 \oplus P_8 \oplus P_9$
5. EVEN OUTPUT =
 $P_1 \oplus P_2 \oplus P_3 \oplus P_4 \oplus P_5 \oplus P_6 \oplus P_7 \oplus P_8 \oplus P_9$

11-2441

A-8 74121 MONOSTABLE MULTIVIBRATOR

The 74121 Monostable Multivibrator features dc triggering from positive or gated negative going inputs. Pulse triggering occurs at a particular voltage level and is not directly related to the transition time of the input pulse. Once fired, the outputs are independent of the input pulses and are dependent only on the timing components on the chip. Input pulses may be of any duration relative to the output pulse.

TRUTH TABLE

t_n INPUT			t_{n+1} INPUT			OUTPUT
A1	A2	B	A1	A2	B	
1	1	0	1	1	1	INHIBIT
0	X	1	0	X	0	INHIBIT
X	1	0	X	0	0	INHIBIT
0	X	0	0	X	1	ONE SHOT
X	0	0	X	0	1	ONE SHOT
1	1	1	X	0	1	ONE SHOT
1	1	1	0	X	1	ONE SHOT
X	0	0	X	1	0	INHIBIT
0	X	0	1	X	0	INHIBIT
X	0	1	1	1	1	INHIBIT
0	X	1	1	1	1	INHIBIT
1	1	0	X	0	0	INHIBIT
1	1	0	0	X	0	INHIBIT

$$1 = V_{in(1)} \geq 2V$$

$$0 = V_{in(0)} \leq 0.8V$$

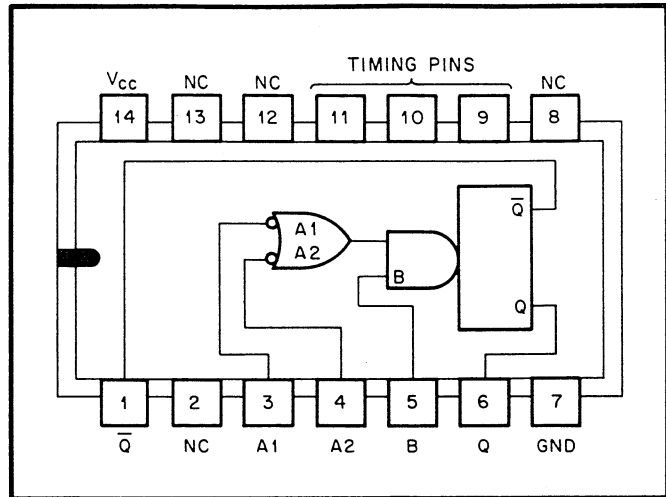

11-1119

- NOTES:
- t_n = time before input transition.
 - t_{n+1} = time after input transition.
 - X indicates that either a logical 0 or 1 may be present.
 - NC = No Internal Connection.
 - A1 and A2 are negative-edge-triggered logic inputs, and will trigger the one shot when either or both go to logical 0 with B at logical 1.
 - B is a positive Schmitt-trigger input for slow edges or level detection, and will trigger the one shot when B goes to logical 1 with either A1 or A2 at logical 0. (See Truth Table).
 - External timing capacitor may be connected between pin ⑩ (positive) and pin ⑪. With no external capacitance, an output pulse width of typically 30 ns is obtained.
 - To use the internal timing resistor (2 k Ω nominal), connect pin ⑨ to pin ⑭.
 - To obtain variable pulse width connect external variable resistance between pin ⑨ and pin ⑭. No external current limiting is needed.
 - For accurate repeatable pulse widths connect an external resistor between pin ⑪ and pin ⑭ with pin ⑨ open-circuit.

Parameter		MIN	TYP	MAX	Units
t_{pd1}	Propagation delay time to logical 1 level from B input to Q output	15	35	55	ns
t_{pd1}	Propagation delay time to logical 1 level from A1/A2 inputs to Q output	25	45	70	ns
t_{pd0}	Propagation delay time to logical 0 level from B input to \bar{Q} output	20	40	65	ns
t_{pd0}	Propagation delay time to logical 0 level from A1/A2 inputs to \bar{Q} output	30	50	80	ns
$t_{p(out)}$	Pulse width obtained using internal timing resistor	70	110	150	ns
$t_{p(out)}$	Pulse width obtained with zero timing capacitance	20	30	50	ns
$t_{p(out)}$	Pulse width obtained using external timing resistor	600	700	800	ns
		6	7	8	ms
t_{hold}	Minimum duration of trigger pulse		30	50	ns

A.9 74154 4-LINE TO 16-LINE DEMULTIPLEXER

The 74154 4-Line to 16-Line Demultiplexer decodes four binary coded inputs into one of 16 mutually exclusive outputs when both strobe inputs (G1 and G2) are low. The demultiplexing function is performed by using the four input lines to address the output line, passing data from one of the strobe inputs with the other strobe input low. When either strobe input is high, all outputs are high.

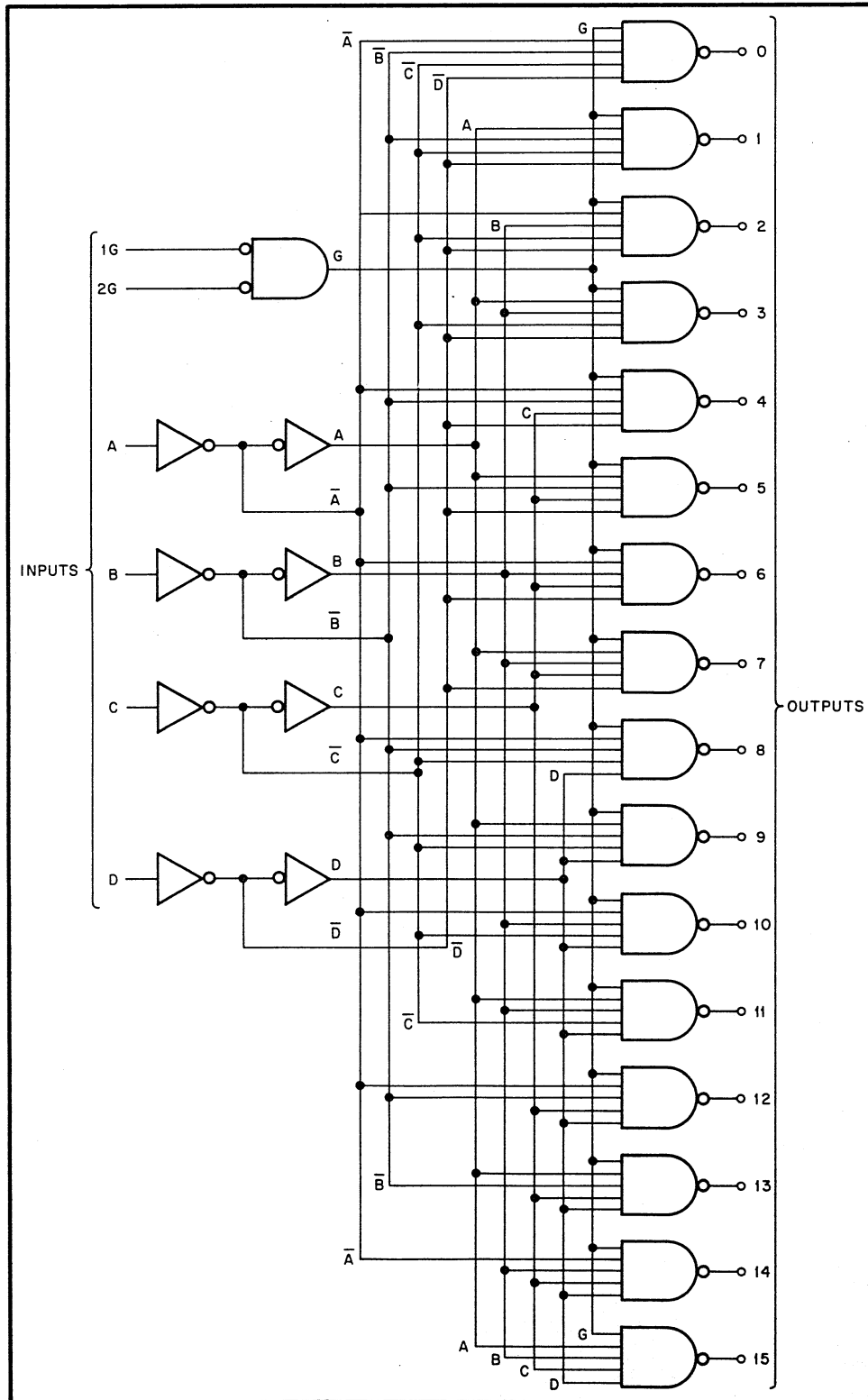

11-0637

TRUTH TABLE

Inputs					Outputs																	
G1	G2	D	C	B	A	0	1	2	3	4	5	6	7	8	9	10	11	12	13	14	15	
L	L	L	L	L	L	L	H	H	H	H	H	H	H	H	H	H	H	H	H	H	H	H
L	L	L	L	L	H	H	L	H	H	H	H	H	H	H	H	H	H	H	H	H	H	H
L	L	L	L	H	L	H	H	L	H	H	H	H	H	H	H	H	H	H	H	H	H	H
L	L	L	L	H	H	H	H	L	H	H	H	H	H	H	H	H	H	H	H	H	H	H
L	L	L	H	L	L	H	H	H	H	L	H	H	H	H	H	H	H	H	H	H	H	H
L	L	L	H	L	H	H	H	H	H	H	L	H	H	H	H	H	H	H	H	H	H	H
L	L	L	H	H	L	H	H	H	H	H	H	L	H	H	H	H	H	H	H	H	H	H
L	L	L	H	H	H	H	H	H	H	H	H	L	H	H	H	H	H	H	H	H	H	H
L	L	H	L	L	L	H	H	H	H	H	H	H	H	L	H	H	H	H	H	H	H	H
L	L	H	L	L	H	H	H	H	H	H	H	H	H	H	L	H	H	H	H	H	H	H
L	L	H	L	H	L	H	H	H	H	H	H	H	H	H	H	L	H	H	H	H	H	H
L	L	H	H	L	L	H	H	H	H	H	H	H	H	H	H	H	L	H	H	H	H	H
L	L	H	H	H	L	H	H	H	H	H	H	H	H	H	H	H	H	H	L	H	H	H
L	L	H	H	H	H	H	H	H	H	H	H	H	H	H	H	H	H	H	H	L	H	H
L	L	H	H	H	H	H	H	H	H	H	H	H	H	H	H	H	H	H	H	H	L	H
L	L	H	H	H	H	H	H	H	H	H	H	H	H	H	H	H	H	H	H	H	H	L
L	H	X	X	X	X	H	H	H	H	H	H	H	H	H	H	H	H	H	H	H	H	H
H	L	X	X	X	X	H	H	H	H	H	H	H	H	H	H	H	H	H	H	H	H	H
H	H	X	X	X	X	H	H	H	H	H	H	H	H	H	H	H	H	H	H	H	H	H

H = high, L = low, X = irrelevant

Signal/Pin Designation

Signal Name	Pin Designation	
Inputs	A	23
	B	22
	C	21
	D	20
	2G	19
	1G	18
	0	1
Outputs	1	2
	2	3
	3	4
	4	5
	5	6
	6	7
	7	8
	8	9
	9	10
	10	11
	11	13
	12	14
	13	15
	14	16
	15	17

DUAL-IN-LINE PACKAGE (TOP VIEW)

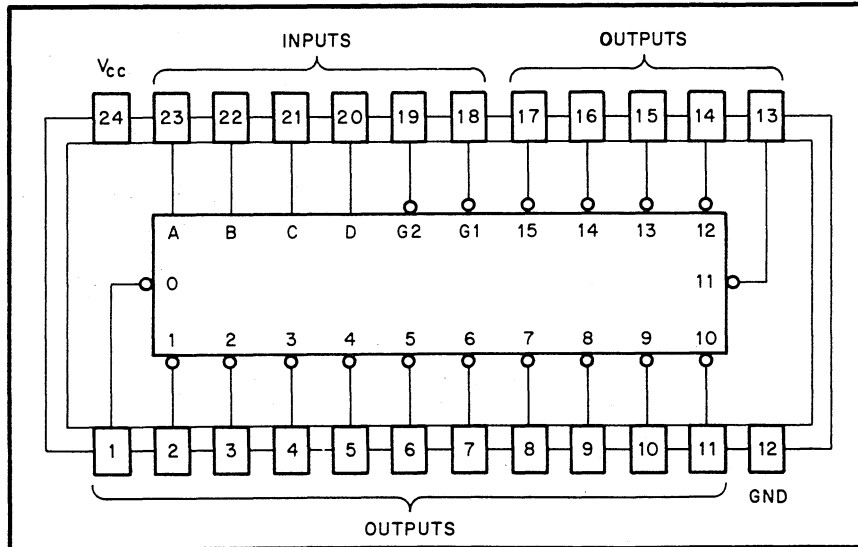

11-0636

Parameter	MIN	TYP	MAX	Unit
t_{PLH} Propagation delay time, low-to-high-level output, from A, B, C, or D inputs through 3 levels of logic		24	36	ns
t_{PHL} Propagation delay time, high-to-low-level output, from A, B, C, or D inputs through 3 levels of logic		22	33	ns
t_{PLH} Propagation delay time, low-to-high-level output, from either strobe input		20	30	ns
t_{PHL} Propagation delay time, high-to-low-level output, from either strobe input		18	27	ns

A.10 75325 MEMORY DRIVERS

The 75325 Memory Drivers contain two source-switch pairs and two sink-switch pairs. Source selection is determined by one of two logic inputs and source turn-on is determined by the source strobe. Sink selection is determined by one of two logic inputs and sink turn-on is determined by the sink strobe. This arrangement allows selection of one of the four switches and its subsequent turn-on with minimum skew of the output current rise.

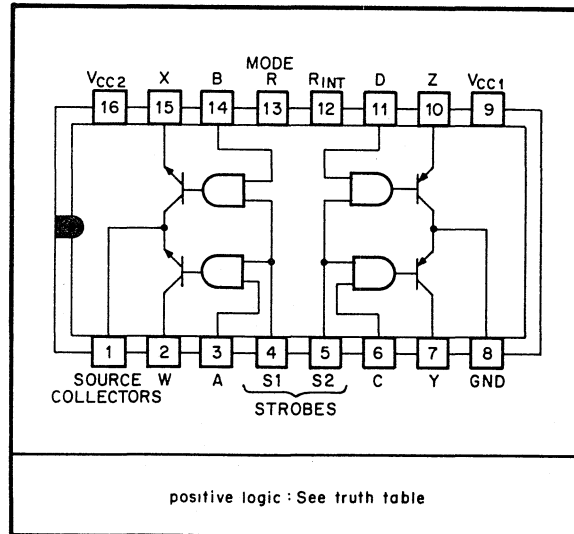

11-2137

TRUTH TABLE

Address Inputs				Strobe Inputs		Outputs			
Source		Sink		Source	Sink	Source		Sink	
A	B	C	D	S1	S2	W	X	Y	Z
L	H	X	X	L	H	ON	OFF	OFF	OFF
H	L	X	X	L	H	OFF	ON	OFF	OFF
X	X	L	H	H	L	OFF	OFF	ON	OFF
X	X	H	L	H	L	OFF	OFF	OFF	ON
X	X	X	X	H	H	OFF	OFF	OFF	OFF
H	H	H	H	X	X	OFF	OFF	OFF	C. F

H = high level, L = low level, X = irrelevant

NOTE: Not more than one output is to be on at any one time.

Parameter§	To (Output)	MIN	TYP	MAX	Unit
t_{PLH}	Source collectors		25	50	ns
t_{PHL}			25	50	
t_{TLH}	Source outputs		55		ns
t_{THL}			7		
t_{PLH}	Sink outputs		20	45	ns
t_{PHL}			20	45	
t_{TLH}	Sink outputs		7	15	ns
t_{THL}			9	20	
t_s	Sink outputs		15	30	ns

§ t_{PLH} = propagation delay time, low-to-high-level output
 t_{PHL} = propagation delay time, high-to-low-level output
 t_{TLH} = transition time, low-to-high-level output
 t_{THL} = transition time, high-to-low-level output
 t_s = storage time

1950

...

...

...

...

...

...

...

...

...

...

...

...

...

...

...

...

...